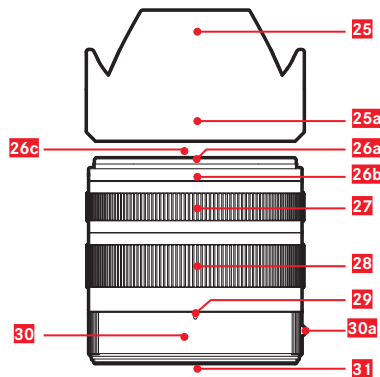
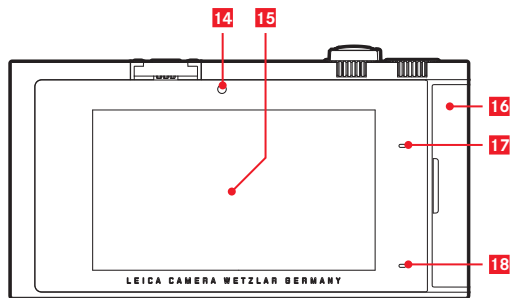
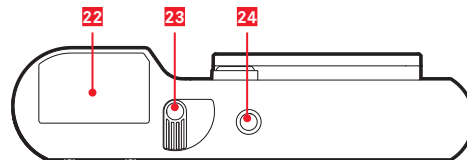
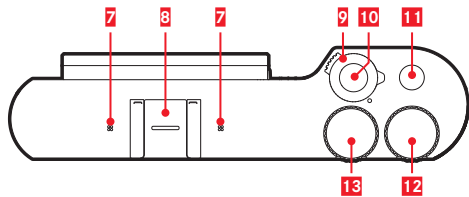
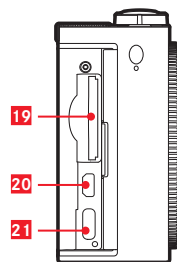
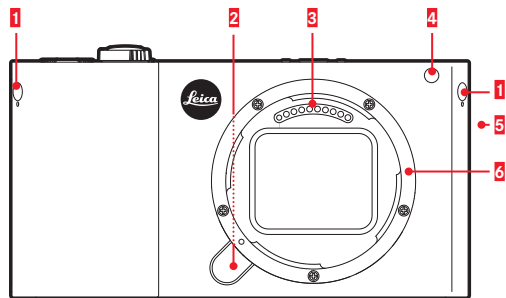




**LEICA TL2**  
Instructions



## DESIGNATION OF PARTS

### CAMERA

#### Front view

- 1** Dummy plugs
- 2** Lens release button
- 3** Contact strip
- 4** Self-timer LED/AF assist light
- 5** Speaker
- 6** Bayonet

#### Top view

- 7** Microphones
- 8** Accessory shoe
- 9** Main switch
- 10** Shutter button
- 11** Function button
- 12** Setting dial
- 13** Setting dial

#### Rear view

- 14** Brightness sensor
- 15** Monitor
- 16** Door over sockets
- 17** Status LED
- 18** Charge status LED

#### View from right (Door opened)

- 19** Memory card slot
- 20** HDMI socket
- 21** USB socket

#### Bottom view

- 22** Battery
- 23** Locking lever
- 24** Tripod thread

### LENS

- 25** Lens hood
  - a. Index points
- 26** Front mount
  - a. External bayonet for lens hood
  - b. Index point for lens hood
  - c. Internal thread for filters
- 27** Distance setting ring
- 28** Focal length setting ring
- 29** Index for focal length
- 30** Fixed Ring
  - a. Red alignment button
- 31** Contact strip

## FOREWORD

Dear Customer,  
we wish you a great deal of pleasure and success using your new Leica TL2.

Please read these instructions in their entirety so that you can make the most of your Leica TL2.

Use the Quick Start Guide for a fast introduction to your new Leica.

## SCOPE OF DELIVERY

Please check the scope of included accessories for completeness before using your Leica TL2 for the first time.

- a. Leica BP-DC13 battery
- b. Battery charger BC-DC13 (including interchangeable mains connector)
- c. USB type C cord
- d. Dummy plug (inserted when delivered)
- e. Carrying strap
- f. Carrying strap plug release key
- g. Body bayonet cap
- h. Accessory shoe cover
- i. Registration card

### Attention:

Always store small parts (e.g. carrying strap plug release key) as follows:

- out of reach of children
- in a location where they will not get lost, e.g. in the designated positions in the camera case

Subject to changes in design and production.

## ACCESSORIES

Please visit the Leica Camera AG website for information on the extensive range of Leica TL2 accessories:

[www.leica-camera.com](http://www.leica-camera.com)

## SPARE PARTS

	<b>Order no.</b>
<b>Body bayonet cap</b>	16 060
<b>Accessory shoe cover</b>	470-701.801-007
<b>Dummy plug</b>	470-701.001-020
<b>Carrying strap plug release key</b>	470-701.001-029
<b>Silicon carrying strap</b>	439-612.100-000
<b>Lithium ion battery BP-DC 13, silver</b>	18 772
<b>Lithium ion battery BP-DC 13, black</b>	18 773
<b>Battery charger Leica BC-DC 13</b>	470-701.022-000
<b>Mains plug set</b>	470-701.801-005
<b>USB type C cord</b>	470-701.001-035

### For United Arab Emirates only:

<p><b>TRA</b>  <b>REGISTERED No:</b>  <b>ER54783/17</b>  <b>DEALER No:</b>  <b>DA0112968/13</b></p>
---

### For US and Canada only:



A recyclable lithium ion/polymer battery powers this camera. Please call 1-800-8-BATTERY for information on how to recycle this battery.

This is a Class B product based on the standard of the Voluntary Control Council for Interference from Information Technology Equipment (VCCI). If this is used near a radio or television receiver in a domestic environment, it may cause radio interference. Install and use the equipment according to the instruction manual.

#### FCC Note:

This equipment has been tested and found to comply with the limits for a Class B digital device, pursuant to Part 15 of the FCC Rules. These limits are designed to provide reasonable protection against harmful interference in a residential installation. This equipment generates, uses, and can radiate radio frequency energy and, if not installed and used in accordance with the instructions, may cause harmful interference to radio communications. However, there is no guarantee that interference will not occur in a particular installation. If this equipment does cause harmful interference to radio or television reception, which can be determined by turning the equipment off and on, the user is encouraged to try to correct the interference by one or more of the following measures:

- Reorient or relocate the receiving antenna.
- Increase the separation between the equipment and receiver.
- Connect the equipment into an outlet on a circuit different from that to which the receiver is connected.
- Consult the dealer or an experienced radio/TV technician for help.

#### FCC Caution:

To assure continued compliance, follow the attached installation instructions and use only shielded interface cables with ferrite core when connecting to computer or peripheral devices. Any changes or modifications not expressly approved by the party responsible for compliance could void the user's authority to operate this equipment.

Trade Name:	LEICA
Type No.	5370
Responsible party/ Support contact:	Leica Camera Inc. 1 Pearl Count, Unit A, Allendale, New Jersey 07401 Tel.: +1 201 995 0051 / Fax: +1 201 995 1684 technicalinfo@leicacamerausa.com

This device complies with Part 15 of the FCC Rules. Operation is subject to the following two conditions: (1) This device may not cause harmful interference, and (2) this device must accept any interference received, including interference that may cause undesired operation.

#### Type No.: 5370



Tested To Comply  
With FCC Standards

FOR HOME OR OFFICE USE

#### Contains FCC ID: VPYLBXN604

This transmitter must not be co-located or operated in conjunction with any other antenna or transmitter. This equipment complies with FCC radiation exposure limits set forth for an uncontrolled environment and meets the FCC radio frequency (RF) Exposure Guidelines. This equipment has very low levels of RF energy that are deemed to comply without testing of specific absorption ratio (SAR).

#### For Canada only:

CAN ICES-3 (B)/NMB-3(B)

This device complies with RSS-210 of the IC Rules. Operation is subject to the following two conditions:

- (1) This device may not cause harmful interference,
- (2) This device must accept any interference received, including interference that may cause undesired operation of the device. This equipment complies with IC radiation exposure limits set forth for an uncontrolled environment and meets RSS-102 of the IC radio frequency (RF) Exposure rules. This equipment has very low levels of RF energy that are deemed to comply without testing of specific absorption ratio (SAR).

#### For Singapore only

Complies with  
IDA Standards  
DA104328

**Attention:**

- Modern electronic components react sensitively to electrostatic discharge. As people can easily pick up charges of tens of thousands of volts by walking on synthetic carpets for example, a discharge can occur when you touch your camera, particularly if it is placed on a conductive surface. If only the camera housing is affected, this discharge is harmless to the electronics. However, despite built-in safety circuits, outer contacts such as those in the flash shoe should not be touched if at all possible for safety reasons.
- For any cleaning of the contacts, do not use an optical micro-fiber cloth (synthetic); use a cotton or linen cloth instead! Before touching the contacts, you can make sure you discharge any electrostatic charge by deliberately touching a heating or water pipe (conductive, grounded material). Please also avoid dirt deposits and oxidation on the contacts by storing your camera in a dry location with the lens cap and flash shoe/viewfinder cap on.
- Use only the recommended accessories to prevent faults, short circuits, or electric shock.
- Do not attempt to remove parts of the housing (covers); repairs must be done at authorized service centers only.

**Important:**

The camera gets warm during use. This is not a malfunction, but rather due to electronic components such as sensor, processor, and monitor generating heat when operating. This happens faster when serial exposures are executed in quick succession or repeatedly for a longer stretch of time, and especially in the case of video recording (4K!). In extreme cases, a protection circuit will shut down the camera. Naturally this will happen the earlier the warmer

the camera was in the first place, e.g. after being inside a vehicle or after being subjected to bright sunlight.

Please take these circumstances into account when planning your shots.

**Legal information:**

- Please ensure that you observe copyright laws. The recording and publication of pre-recorded media such as tapes, CDs, or other published or broadcast material may contravene copyright laws.
- This also applies to all of the software supplied.
- With regard to videos created using this camera: This product is licensed under the AVC Patent Portfolio license for the personal use of a consumer or other uses in which the consumer does not receive remuneration to (i) encode video in compliance with the AVC standard ("AVC video") and/or (ii) decode AVC video that was encoded by a consumer engaged in a personal activity and/or was obtained from a video provider licensed to provide AVC video. No license is granted or shall be implied for any other use. For more information please visit the MPEG LA, L.L.C. website at <http://www.mpegla.com>. Any other use, including but not limited to providing AVC video in exchange for remuneration, may require a separate license agreement with MPEG LA, L.L.C. For more information please visit the MPEG LA, L.L.C. website at <http://www.mpegla.com>.
- The SD and USB logos are registered trademarks.
- Other names, company and product names referred to in these instructions are trademarks or registered trademarks of the respective companies.



## Disposal of electrical and electronic equipment

(Applies within the EU, and other European countries with segregated waste collection systems)

This device contains electrical and/or electronic components and must therefore not be disposed of in general household waste! Instead, it should be disposed of at a recycling collection point provided by the local authority. This costs you nothing. If the device contains standard or rechargeable batteries, these must be removed first and also be disposed of in line with relevant regulations. Further information on the subject is available from your local administration, your local waste collection company, or in the store where you purchased this device.

## The CE identification of our products documents compliance with the fundamental requirements of the applicable EU directives.

### English

#### Declaration of Conformity (DoC)

Hereby, "Leica Camera AG" declares that this product is in compliance with the essential requirements and other relevant provisions of Directive 2014/53/EU.

Customers can download a copy of the original DoC to our RE products from our DoC server:  
[www.cert.leica-camera.com](http://www.cert.leica-camera.com)

In case of further questions, please contact:  
Leica Camera AG, Am Leitz-Park 5, 35578 Wetzlar, Germany

#### Wireless transmitter:

Frequency range used:

2412 MHz to 2462 MHz (Central frequency - WLAN)

2402 MHz to 2480 MHz (Central frequency - Bluetooth® wireless technology)

Max. output power: 20 dBm (EIRP)

## Meaning of the different categories of information in this manual

### Note:

Additional information

### Important:

Failure to observe the instructions may cause damage to the camera, accessories or the photos

### Attention:

Failure to observe the instructions may cause personal injury

The production date of your camera can be found on the stickers in the warranty card and/or on the packaging. The format is: Year/ Month/Day

The specific approvals for this device can be found in the camera menu.

- ▶ In the main menu, select



- ▶ Select
- ▶ Select **Regulatory information** in the submenu.

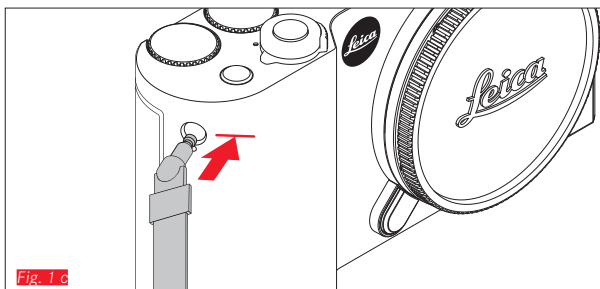
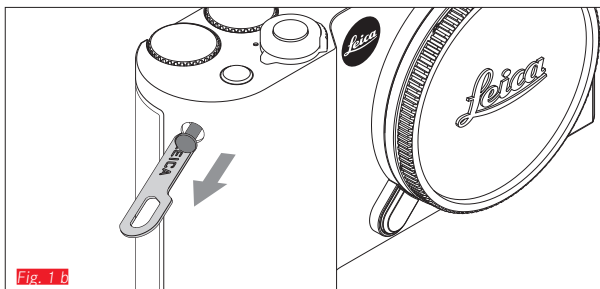
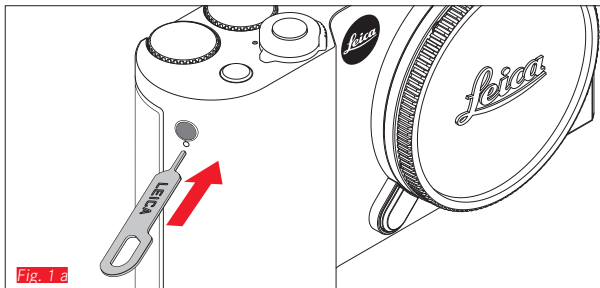


## TABLE OF CONTENTS

<b>Designation of parts</b> .....	109
<b>Foreword</b> .....	110
<b>Scope of Delivery</b> .....	110
<b>Accessories</b> .....	110
<b>Spare parts</b> .....	110
<b>Preparations</b>	
Attaching the carrying strap .....	116
Changing the battery .....	117
Charging the battery .....	118
Changing the memory card .....	122
Attaching/detaching the lens .....	124
Compatible lenses .....	124
<b>Camera operation</b>	
Main switch .....	126
Setting dials .....	126
Shutter button .....	127
Function button .....	127
Gesture control .....	128
Locking/unlocking the right toolbar .....	129
<b>INFO</b> displays .....	130
Opening the exposure mode/scene mode menu .....	131
Opening the <b>MY CAMERA</b> menu .....	131
Opening the main menu .....	131
Main menu structure .....	131
Opening a menu item in one of the main menu function groups .....	131
Navigation in the main and <b>MY CAMERA</b> menus .....	132
Menu tiles .....	133
Direct setting of function options .....	133
Selecting a menu item and setting function options in submenus .....	134
Settings in submenus with setting dials and gesture control .....	135
Customizing the <b>MY CAMERA</b> menu .....	136
Setting dial menu .....	138
Locking the setting dial functions .....	138
Assigning the desired function to the left setting dial .....	139
<b>Basic camera settings</b>	
Menu language .....	140
Date/time .....	140
Automatic Camera Shutdown .....	141
Acoustic signals .....	142
Monitor/viewfinder settings .....	142
Automatic Monitor Shutdown .....	143
<b>Basic picture settings</b>	
File format/compression rate .....	144
White balance .....	145
ISO Sensitivity .....	146
JPEG image properties .....	146
<b>Additional picture settings</b>	
Image stabilization .....	148
Self-Timer .....	148
Recording the location with GPS .....	149
<b>Picture mode</b>	
Serial exposures .....	150
Focusing .....	150
Autofocus .....	150
AF Auxiliary Light .....	151
Autofocus metering methods/Operating modes .....	152
Spot/single point metering .....	152
Touch AF/Touch AF + Shutter release .....	154
Multi-zone metering .....	155
Face detection .....	155
Manual focusing .....	156
Auxiliary function for manual focusing .....	156



<b>Exposure metering and control</b>	
Exposure Metering Methods .....	158
Exposure control.....	158
Program mode - P.....	159
Aperture priority - A.....	160
Shutter speed priority - S.....	161
Manual setting - M.....	162
Histogram .....	163
Clipping.....	164
Scene modes .....	165
Metering memory lock.....	166
Exposure compensation.....	166
Automatic exposure bracketing.....	167
<b>Flash Photography</b>	
Compatible flash units .....	168
Attaching a flash unit.....	168
Flash modes .....	169
Flash range .....	170
Synchronization time point.....	171
Flash exposure compensation.....	171
<b>Video recording</b> .....	172
Stabilization .....	173
Starting/ending the recording.....	173
Sound recording .....	173
<b>Review mode</b>	
Continuous review mode .....	174
Automatic review .....	174
Viewing Pictures in Portrait Format .....	175
Selecting pictures .....	175
Enlarging/reducing pictures.....	176
Simultaneous display of 9 pictures.....	176
Selecting a cropped section.....	177
Review menu .....	178
Slide show .....	178
Marking pictures as favorites/canceling markings.....	179
Protecting pictures/clearing delete protection.....	179
<b>Deleting images</b> .....	180
<b>Selecting the playback source</b> .....	182
<b>Copying picture data between the internal memory and the inserted memory card</b> .....	182
<b>Video review</b> .....	184
<b>Cutting and combining video recordings</b> .....	186
<b>Miscellaneous</b>	
User profiles .....	188
Resetting all custom settings .....	190
Resetting the image file numbering .....	191
Setting up and using the WiFi function .....	192
Transferring data to a computer .....	196
Formatting .....	197
Using raw data (DNG) .....	198
Installing firmware updates.....	198
<b>Safety and care instructions</b> .....	199
<b>Appendix</b>	
Charger adapter plugs .....	203
Main menu .....	204
Exposure mode menu .....	207
<b>Index</b> .....	208
<b>Technical data</b> .....	210
<b>Leica service addresses</b> .....	212



## ATTACHING THE CARRYING STRAP

## CHANGING THE BATTERY

Turning off the camera [Fig. 2 a](#)

Inserting the battery [Fig. 2 b](#)

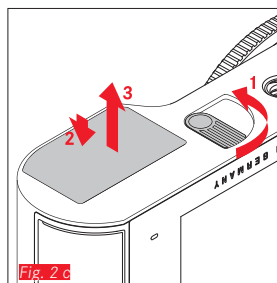
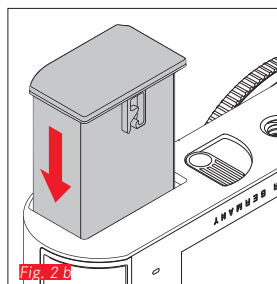
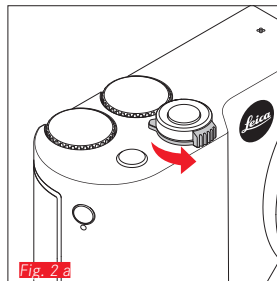
Removing the battery [Fig. 2 c](#)

### Notes:

- The battery is supplied pre-charged, which means that you can start using the camera immediately.
- The lock has a retaining mechanism to prevent the battery from falling out when the camera is held upright.

### Important:

Removing the battery with the camera turned on can result in your settings being deleted, a loss of picture data, and damage to the memory card.



## CHARGING THE BATTERY

Your Leica TL2 is powered by a Lithium-ion battery. It can be charged while inserted in the camera using the USB cord supplied or outside the camera using the charger supplied.

### Attention:

- Only the battery types specified and described in this manual and/or specified and described by Leica Camera AG may be used in this camera.
  - This battery may only be used in the units for which it is designed and may only be charged exactly as described.
  - Using the battery contrary to these instructions and using battery types not specified in these instructions may result in an explosion.
  - The batteries must not be exposed to sunlight, heat, humidity or condensation for extended periods. Batteries must not be placed in a microwave oven or in a high-pressure vessel, as this may cause an explosion.
  - Never throw batteries into a fire, as this may cause an explosion!
  - Damp or wet batteries must not be charged or used in the camera under any circumstances.
  - Always ensure that the battery contacts are clean and freely accessible.
  - Whilst lithium ion batteries are secured against short circuits, they should still be protected against contact with metal objects like paper clips or jewelry. A short-circuited battery can get very hot and cause severe burns.
  - If a battery is dropped, check the casing and the contacts immediately for any damage. Using a damaged battery can damage the camera.
- A battery must be removed from the camera or charger immediately and replaced if it develops noise, becomes discolored, deformed, or overheated or if it shows any sign of leakage. Continued use of a damaged battery may cause overheating and a risk of fire and/or explosion.
  - If liquid leaks out or you smell burning, keep the batteries away from heat sources. Leaked fluid can catch fire.
  - Only the charger specified and described in this manual, or chargers specified and described by Leica Camera AG, may be used. The use of other chargers that are not approved by Leica Camera AG can cause damage to the batteries and, in extreme cases, serious or life-threatening injuries.
  - The charger supplied should be used exclusively for charging this battery type. Do not attempt to use it for other purposes.
  - Ensure that the power socket used is freely accessible.
  - Heat is generated during charging. Therefore batteries must not be charged in small, enclosed or unventilated spaces.
  - The battery and charger must not be opened. Repairs may only be carried out by authorized service centers.
  - Keep batteries out of the reach of children. Swallowing batteries can cause suffocation.

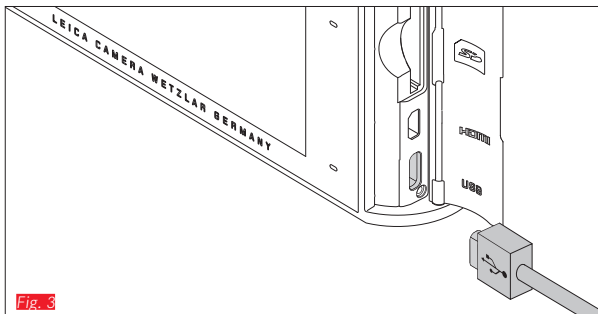
**Dispose of used batteries in line with the information provided in these instructions.**

**First Aid:**

- Battery fluid coming into contact with the eyes may cause blindness. Immediately rinse the eyes thoroughly with clean water. Do not rub the eyes. Seek medical attention immediately.
- If leaked fluid gets onto the skin or clothing, there is a risk of injury. Rinse the affected areas with clean water.

**Notes:**

- The battery is supplied partially charged, but it should be charged before long periods of use.
  - In order to charge the battery, it must have a temperature of between 0°C and 35°C/32°F and 95°F (otherwise the charger may not turn on or off again).
  - Lithium-ion batteries can be charged at any time, regardless of their current charge level. If a battery is only partly discharged when charging starts, it is charged to full capacity faster.
  - Lithium ion batteries should only be stored partly charged, i.e. not when fully discharged or fully charged. For very long storage periods, batteries should be charged for around 15 minutes twice a year to prevent total discharge.
  - The batteries warm up during the charging process. This is normal and not a malfunction.
  - A new battery only reaches its full capacity after it has been fully charged and – by use in the camera – discharged 2 or 3 times. This discharge procedure should be repeated roughly every 25 cycles.
- Rechargeable lithium-ion batteries generate power through internal chemical reactions. This reaction is influenced by ambient temperature and humidity. To maximize the life of the battery, it should not be exposed to extremely high or low temperatures for long periods (e.g. in a parked car in summer or winter).
  - Even with optimum conditions of use, every battery has a limited service life. After several hundred charging cycles, this becomes noticeable as the operating times get significantly shorter.
  - In line with the applicable regulations (see p. 113), defective batteries should be disposed of at an appropriate collection point for proper recycling.
  - The replaceable battery supplies another back-up battery that is built into the camera. This back-up battery ensures that the date and time data entered is retained for up to 2 days. If this back-up battery runs out it must be recharged by inserting a charged main battery. Once the replaceable battery has been inserted, the full capacity of the back-up battery is recovered after about 60 hours. This process does not require the camera to be turned on. However, the date and time will have to be set again.
  - Remove the battery if you will not be using the camera for a long period of time. Turn the camera off using the main switch before removing the battery. Otherwise, after several weeks the battery could become totally discharged, i.e. the voltage is sharply reduced as the camera still consumes a small amount of current (for saving your settings) even when it is turned off.



## CHARGING THE BATTERY (CONT.)

### WITH USB CABLE [Fig. 3](#)

#### Notes:

- The camera should only be connected to a computer or a standard USB charger (with a maximum charging current of 500 mA or 1 A) and not to a monitor, keyboard, printer, or USB hub.
- The USB charging process is only started when the camera is turned off.
- If the computer goes into standby mode during charging, this may cancel the charging process.

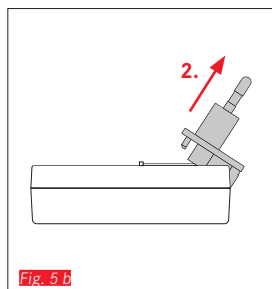
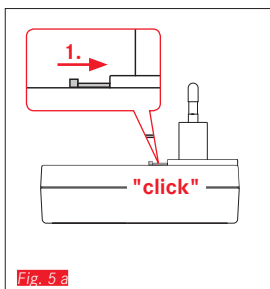
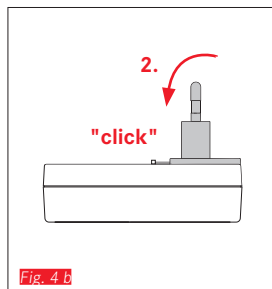
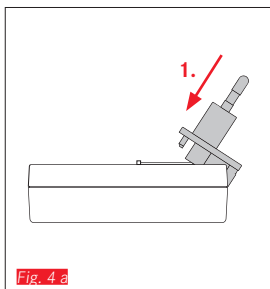
#### Important:

- Use only the USB cable supplied.

### WITH THE CHARGER

#### Changing the mains connector on the charger

#### Inserting [Fig. 4 a/b](#)



#### Removing [Fig. 5 a/b](#)

## Inserting the battery in the charger [Fig. 6](#)

## Removing the battery from the charger [Fig. 7](#)

### Notes:

- The charger must be fitted with the appropriate plug for the local sockets.
- The charger automatically adjusts to the relevant mains voltage.

## Charge status displays

The charging process is indicated by LEDs.

With USB cable (LED on camera) [Fig. 8](#)

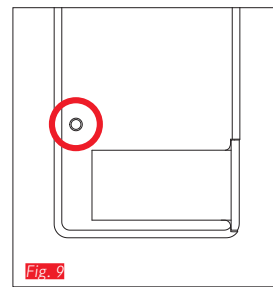
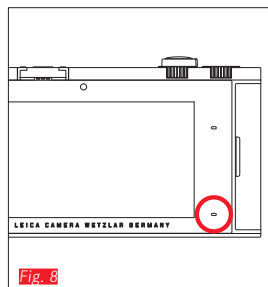
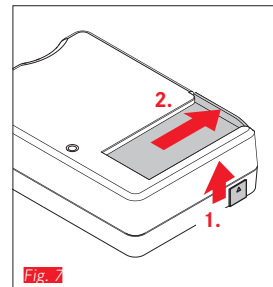
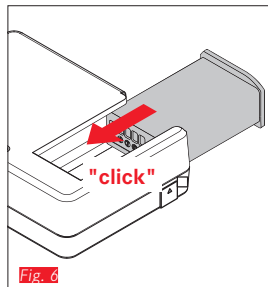
- continuously red: Charging
- continuous green: Battery fully charged.

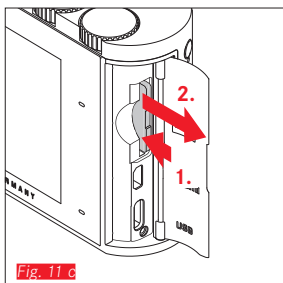
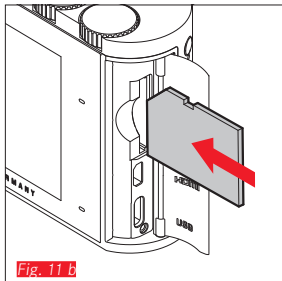
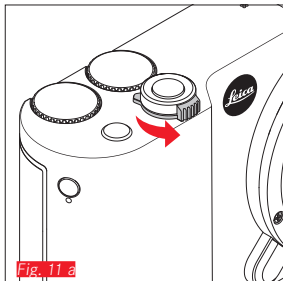
With charger (LED on charger) [Fig. 9](#)

- flashing red: Fault, no charging
- continuously red: Charging
- continuous green: Battery fully charged.

## Charge level display [Fig. 10](#)

The charge level of the battery inserted is indicated in the monitor. The display flashes if the battery only has capacity for a few more pictures. At this point, the battery should be replaced or recharged.





## CHANGING THE MEMORY CARD

SD, SDHC or SDXC memory cards can be used in the Leica TL2.

However, thanks to an internal 32 GB memory you can also take photos without a memory card.

**Turning off the camera** [Fig. 11a](#)

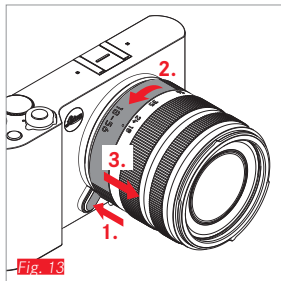
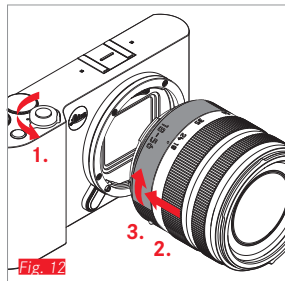
**Inserting the memory card** [Fig. 11b](#)

**Removing the memory card** [Fig. 11c](#)



**Notes:**

- Do not open the compartment and do not remove the memory card or the battery while the LED is lit to indicate that the camera is accessing the memory. Otherwise, the data on the card may be destroyed and malfunctions can occur in the camera.
- SD, SDHC, and SDXC memory cards have a write protection switch, which can be used to prevent unintentional storage and deletion of pictures. This switch takes the form of a slider on the non-beveled side of the card; in the lower position, marked LOCK, the data is protected.
- If the memory card cannot be inserted, check that it is aligned correctly.
- If a memory card is inserted, pictures are only saved on the card. If no card is inserted, the camera stores image data in the internal memory.
- For **4K** video recording (see p. 172), memory cards with fast read/write speeds should be used, preferably with at least Class U3 and/or V30 standard. Using slower cards may result in the recording being aborted immediately after reaching the internal buffer capacity limit.
- The range of SD/SDHC/SDXC cards is too large for Leica Camera AG to be able to completely test all available types for compatibility and quality. Although no damage to the camera or the card is generally expected, because some "no name" cards may not fully comply with the SD/SDHC/SDXC standards Leica Camera AG cannot provide any guarantee of function.
- As electromagnetic fields, electrostatic charge, and defects on the camera or the card can lead to damage or loss of the data on the memory card, we recommend that you also transfer the data to a computer and save it there.



## ATTACHING THE LENS Fig. 12

## DETACHING THE LENS Fig. 13

### Notes:

- To protect against dust getting into the interior of the camera, it is important always to have a lens or a cover attached to the camera body.
- For the same reason, when changing lenses work quickly and in an environment that is as dust-free as possible.
- Camera or lens rear covers should not be stored in your pants pocket as they attract dust that can get into the camera when they are fitted.

## COMPATIBLE LENSES

All Leica TL lenses essentially have the same external design: they have an external bayonet on the front mount for the lens hood and an internal thread for filters, a setting ring for the distance, a fixed ring with a red index button for changing lens, and a contact strip for transferring information and control signals.

Leica TL zoom lenses also have an additional focal length setting ring with its own index.

Apart from Leica TL lenses, Leica SL lenses can be attached with their L bayonet to the Leica TL2, making full use of all their functions.

## Depth of field

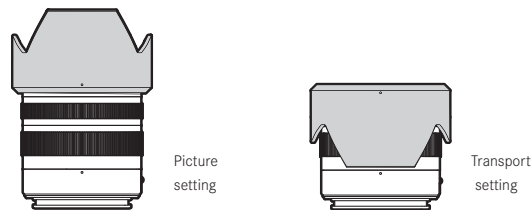
As Leica TL lenses do not have an aperture ring, there is no depth of field scale. For the corresponding values, refer to the tables on the Leica Camera AG website.

## Exposure metering and control with zoom lenses for the Leica TL2

Zoom lenses for the Leica TL2 have a variable maximum aperture opening depending on the focal length set. To prevent incorrect exposures, the desired focal length must be determined before storing the measured value or changing the speed/aperture combination. For further details, refer to the sections under "Exposure metering and control" starting on p. 158.

When using non-system compatible flash units, the aperture setting on the flash unit must correspond to the actual aperture.

## Lens hood



Leica TL lenses are supplied with optimized lens hoods. Thanks to their symmetrical bayonet, they can be attached quickly and easily including in reverse for space-saving storage.

Lens hoods reduce stray light and reflections, as well as preventing damage and dirt on the front lens.

## FILTERS

Screw-on filters can be used on lenses for Leica TL2. For the appropriate diameter, refer to the technical data in the relevant lens instructions.

## CAMERA OPERATION

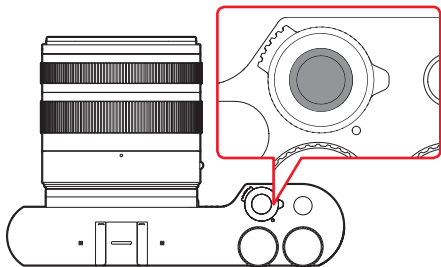


Fig. 14

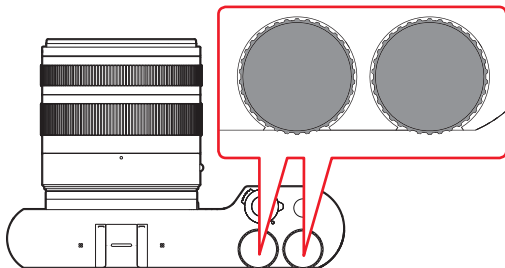


Fig. 15

**MAIN SWITCH** Fig. 14

The Leica TL2 is turned on and off with the main switch:

- Red dot visible = Turned off
  - Red dot not visible = Turned on
- The monitor image appears when the camera is turned on.

**Note:**

The first time you turn on, or when you turn on after resetting all settings, **PLAY ▶** appears in the top right of the monitor. Pressing this display starts a welcome video. Playback can be stopped at any time by touching **SKIP ▶**.

The **LANGUAGE** submenu then appears, and when you have made the settings the **DATE/TIME** submenu, and finally, once you have made the settings here, the monitor screen.

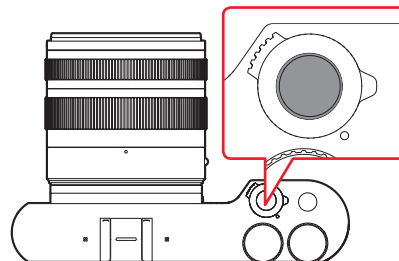
**SETTING DIALS** Fig. 15

The two setting dials on the Leica TL2 are allocated different functions in picture, review and menu control modes.

**SHUTTER BUTTON** Fig. 16

The shutter button works in two stages. Lightly pressing activates both automatic distance setting and exposure metering and control, and stores the relevant settings/values. If the camera was previously in standby mode, this reactivates it and the monitor image appears again.

Pressing the shutter button all the way down takes a picture.

**Fig. 16****FUNCTION BUTTON** Fig. 17

You can assign different functions to this button.



Video button (default setting)

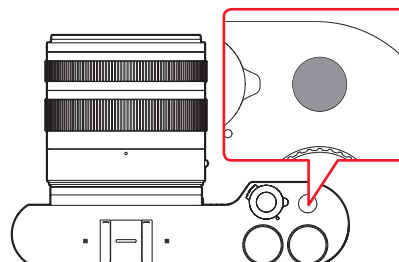


Switching from picture to review mode



Turn on viewfinder permanently

Assignment and function are described in the respective sections.

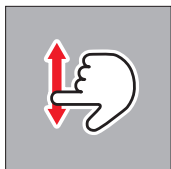
**Fig. 17**



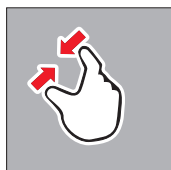
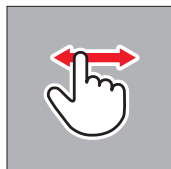
Tap briefly



Tap twice

Long touch, drag and  
release

Swipe



Push together



Pull apart

## GESTURE CONTROL

The Leica TL2 is predominantly operated using the gestures listed on the left on the touch-sensitive monitor.

**Note:**

A light touch is enough, do not press.

## Right toolbar [Fig. 18 a/b](#)

The symbols at the right edge of the monitor are the entry point for operating the Leica TL2. To prevent unintentional operation, you can disable these symbols.

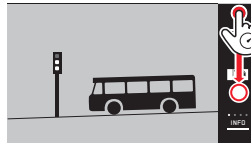
## Disabling [Fig. 19 a/b](#)

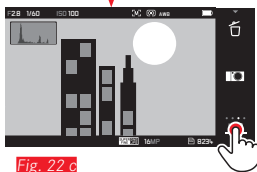
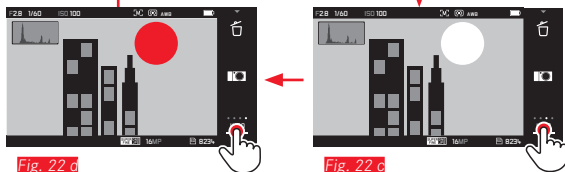
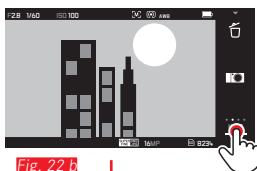
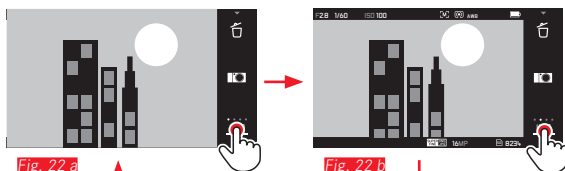
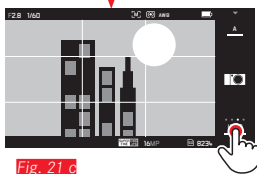
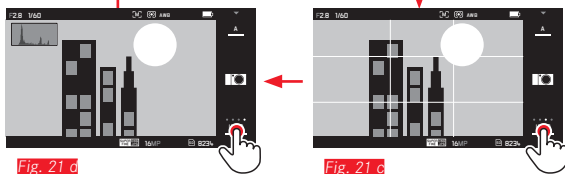
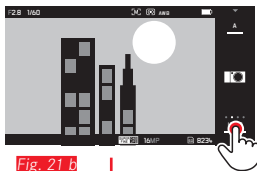
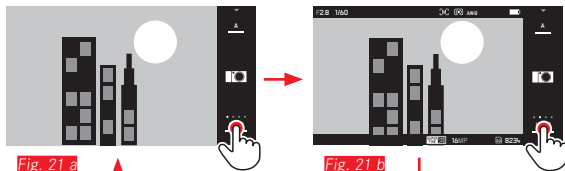
## Releasing [Fig. 20 a/b](#)

Picture mode

[Fig. 18 a](#)

Review mode

[Fig. 18 b](#)[Fig. 19 a](#)[Fig. 19 b](#)[Fig. 20 a](#)[Fig. 20 b](#)



## INFO displays

Repeatedly touching **INFO** allows you to select the monitor display according to your desired information set.

### In picture mode *Fig. 21 a-d*

- 1x = Status displays in header and footer
- 2x = Grid
- 3x = Histogram
- 4x = No additional information (default setting)

### In review mode *Fig. 22 a-d*

- 1x = Status displays in header and footer
- 2x = Histogram
- 3x = Clipping and histogram
- 4x = No additional information (default setting)

### Notes:

- In addition, a distance scale appears when focusing manually.
- Details on the histogram and clipping displays, see p. 163/164.



### Opening the exposure mode/scene mode menu [Fig. 23 a/t](#)


- ▶ touch symbol in the toolbar on top

### Opening the MY CAMERA menu [Fig. 24 a/t](#)

- ▶ Touch  symbol

This menu can be individually configured with functions from the main menu. This gives you faster access to the functions you use most frequently.

### Opening the main menu [Fig. 25 a-c](#)

- ▶ touch  symbol in the MY CAMERA menu

The main menu provides access to all menu items on the camera.

### Main menu structure

The 9 tiles of the main menu are the access point to the respective function groups. Each of these groups contain different numbers of menu items.

### Accessing the menu items in a main menu function group [Fig. 26 a/b](#)

Touch the respective tile to call up its menu items.

↶ = Back to the previous menu level/setting, or close menu altogether



Fig. 23 a



Fig. 23 b



Fig. 24 a



Fig. 24 b



Fig. 25 a



Fig. 25 b

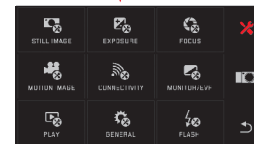


Fig. 25 c



Fig. 26 a

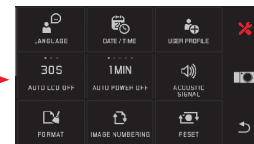


Fig. 26 b

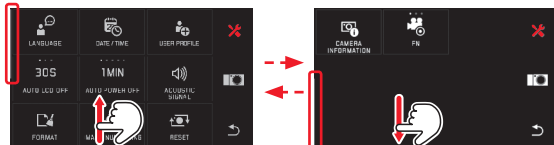


Fig. 27 a

Fig. 27 b

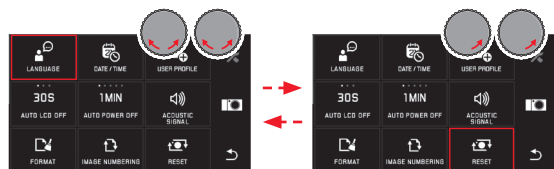


Fig. 28 a

Fig. 28 b

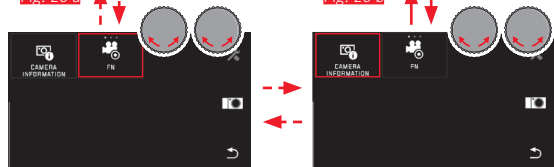


Fig. 28 c

Fig. 28 d

## Navigation in the main and MY CAMERA menus

The camera provides two different options for navigating in the menus, the submenus, and the menu items.

- With gesture control and setting dials (Fig. 27 a/b)
- Using the setting dials (both have the same function in this case) and gesture control (Fig. 28 a-d)
- Main menu function groups containing more than nine menu items list these on two pages. This can also be the case in the **MY CAMERA** menu. If so, a scrollbar appears on the left, indicating the current position within that menu.

### Note:

Menu items that are not available, e.g. because of other settings, are indicated by a gray display - instead of white - and are skipped.

## Menu tiles

The main menu function groups as well as menu items are displayed in the form of tiles.

### Information in the menu item tiles

**Fig. 29 a** Display for a tile without submenu; function options (max. 5) are set directly


**Fig. 29 a-c** Changing the order of menu items

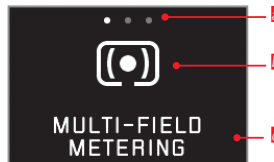
**Fig. 29 a-d** Name of the menu item and/or the set menu function.

Depending on the scope of the menu item, the tile provides:

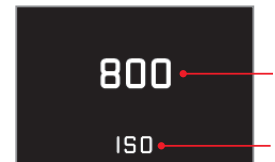
- Direct setting of the function options, or
- Access to a submenu

### Direct setting of function options

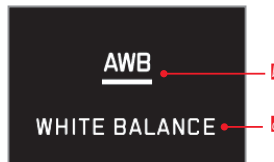
For menu tiles that can be set directly, the next function option is accessed simply by touching  it **Fig. 30 a-c**.



**Fig. 29 a**



**Fig. 29 b**



**Fig. 29 c**



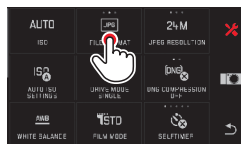
**Fig. 29 d**

**a** Display for directly selectable function options,

number of dots = available options

**b** Symbol/abbreviation for selected option or value setting

**c** Name of function/tile, or selected option



**Fig. 30 a**



**Fig. 30 b**



**Fig. 30 c**

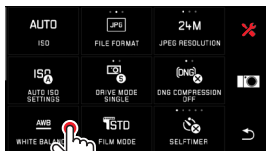


Fig. 31 a

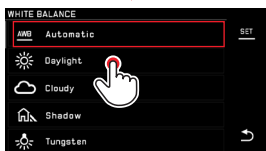


Fig. 31 b

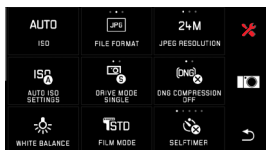


Fig. 31 d

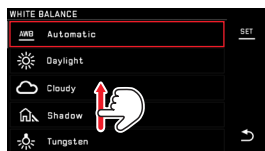


Fig. 31 c



Fig. 31 e



Fig. 31 i

## Selecting a menu item and setting function options in submenus

Menu items that only have the displays **b** and **c** are set using submenus. Their structure differs depending on the function.

### With gesture control [Fig. 31 a-f](#)

Swiping scrolls through the submenu list a line at a time.

### Notes:

- Marked submenu items can also be set at any time by touching **SET** in the toolbar on the right.
- A submenu can include two pages. In such a case, a progress bar on the left indicates on which page you are at any time.

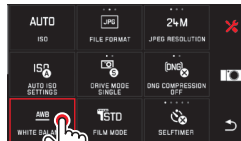
### Settings in submenus with setting dials and gesture control [Fig. 32 a-e](#)

Using the setting dials (both have the same function in this case) function - can be used to select individual options in submenus.

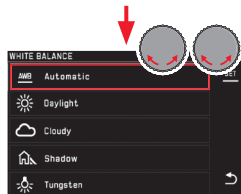
If you continue turning beyond the first or last submenu option on a page, the submenu list 'jumps' by a page, i.e. the next or previous lines appear. This also applies to the start and end of the submenu list (=> "endless loop").

### General comments on menu control

- Settings for options that differ from the above explanations or include additional steps are described in the sections dealing with the relevant options.
- Some menu items may not be available, e.g. because the relevant functions have fixed settings in the scene modes, or because the external viewfinder (available as an accessory) they are related to is not attached. These options are then indicated by a gray function icon (instead of white) and cannot be selected.
- The menu is normally opened at the position of the last option set.



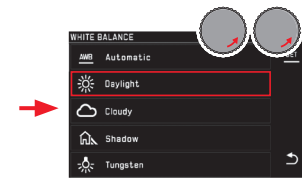
[Fig. 32 a](#)



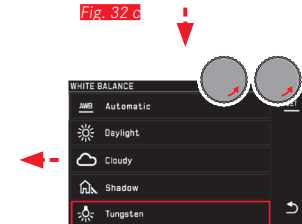
[Fig. 32 b](#)



[Fig. 32 c](#)



[Fig. 32 d](#)



[Fig. 32 e](#)

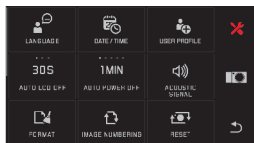


Fig. 33 a

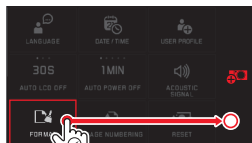


Fig. 33 b

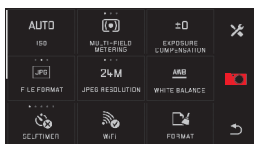


Fig. 33 c

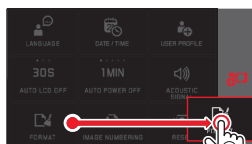


Fig. 33 d

## Customizing the MY CAMERA menu

A number of functions are preset as default in the **MY CAMERA** menu.

Every **MY CAMERA** menu item's position in it can be changed, and every menu item in the main menu function groups can be added or deleted. This free menu design allows you to individually configure the camera to match your own needs and provides faster access to the functions you use most frequently.


## Adding menu options Fig. 33 a-d

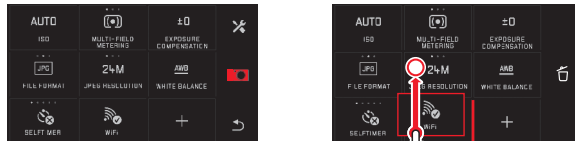
Menu items can be added using the gesture .

### Changing the order of menu items **Fig. 34 a-c**

The menu items are initially displayed in the order of selection. However, this order can be changed at any time.

### Deleting menu items **Fig. 35 a-c**

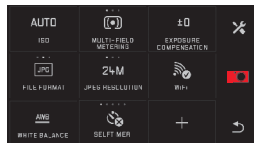
All menu items can be removed from the **MY CAMERA** menu by dragging them to .



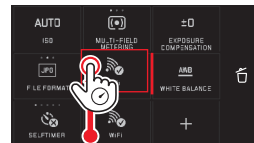
**Fig. 34 a**



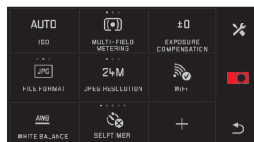
**Fig. 34 b**



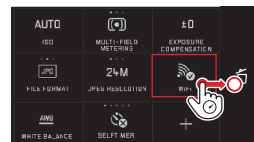
**Fig. 34 c**



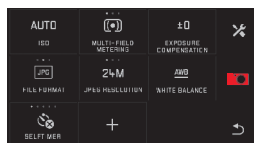
**Fig. 34 d**



**Fig. 35 a**



**Fig. 35 b**



**Fig. 35 c**



**Fig. 35 d**

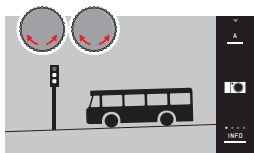


Fig. 36 a

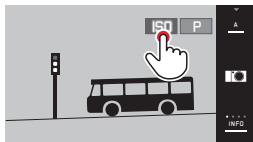


Fig. 36 b



Fig. 36 c

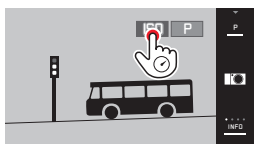


Fig. 37 a



Fig. 37 b

## Setting dial menu

In aperture priority, shutter speed priority and automatic program modes, the right setting dial is assigned the aperture, shutter speed and program shift functions respectively. In these modes, the functions represented by the six tiles shown in Fig. 36 c can be assigned to the left setting dial. The factory default is **ISO**.

## Opening the main menu Fig. 36 a-c

The setting dial function displays appear when one of the dials is turned by one detent position. Touching the left function display brings up the available function tiles.

## Locking/unlocking the setting dials Fig. 37 a/b

The setting dial functions can be locked/unlocked by touching the respective function displays for a long time. This is possible with both setting dials.



## Assigning the desired function to the left setting dial

With gesture control [Fig. 38 a/b](#)

With a setting dial and gesture control [Fig. 39 a-f](#)

### Note:

Regardless of which of the function tiles is active in the menu list (outlined in red) any of them can be selected at any time by touching it.

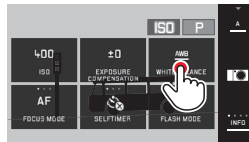


Fig. 38 a



Fig. 38 b

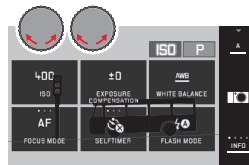


Fig. 39 a

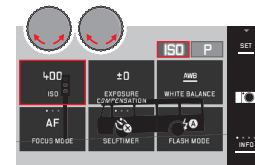


Fig. 39 b

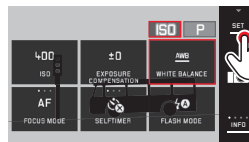


Fig. 39 c

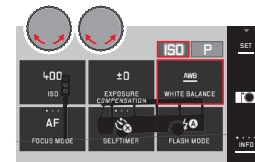


Fig. 39 d

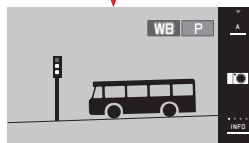


Fig. 39 e

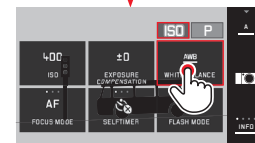




Fig. 39 f

## BASIC CAMERA SETTINGS

### MENU LANGUAGE

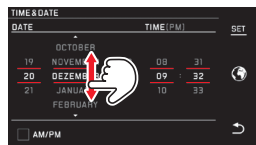
- ▶ In the main menu, select 
- ▶ Select 
- ▶ Select the desired language in the submenu

### DATE/TIME

- ▶ In the main menu, select 
- ▶ Select 

### Setting the date/time [Fig. 40](#)

These settings are made in the same way in all five 'columns'.

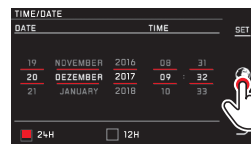


[Fig. 40](#)

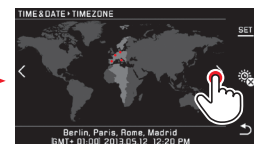
- ▶ Press **SET** to confirm

### Selecting the time zone [Fig. 41 a-c](#)

Each touch or drag advances the setting by one time zone.



[Fig. 41 a](#)



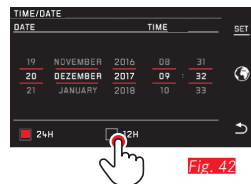
[Fig. 41 b](#)



[Fig. 41 c](#)

- ▶ Press **SET** to confirm

### Selecting the time format [Fig. 42](#)



[Fig. 42](#)

- ▶ Press **SET** to confirm

## Activating/deactivating daylight saving time Fig. 43 a/b

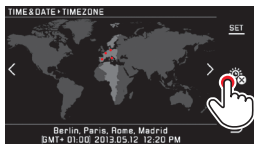



Fig. 43 a



Fig. 43 b

-  = off,  = on

- ▶ Touch **SET** to confirm

### Note:

Even if no battery is inserted or if the battery is flat, the date and time settings are retained for around 2 days thanks to the built-in back-up battery. However, after this time they have to be reset.

## Automatic Camera Shutdown

If this function is activated, the camera switches to energy-saving standby mode after the selected time (1/2/5/10/20 min).

- ▶ In the main menu, select



- ▶ Select



### Notes:

- When the camera is in standby mode, it can be turned on at any time by pressing the shutter button or by turning it off and on with the main switch.

## Acoustic signals

On the Leica TL2 you can set whether you want particular operations or a full memory card to be indicated by tones, or whether you prefer operation of the camera and photography itself to be largely quiet.

▶ In the main menu, select



▶ Select



▶ Select the required settings in the **Volume**, **Click**, **SD card full**, **AF Confirmation** submenus (**OFF**, **LOW**, **HIGH**)

## Monitor/viewfinder settings

For optimum visibility and to adapt to different lighting conditions, the brightness and color reproduction can be adjusted.

### Notes:

- The operations described below using the example of the monitor settings also apply to the viewfinder settings, i.e. for the **EVF BRIGHTNESS** and **EVF COLOR ADJUSTMENT** menu items. If the Leica Visoflex external electronic viewfinder available as an accessory is not attached, these menu options cannot be selected and the relevant function icons are grayed out.
- The viewfinder is turned on automatically - and the camera monitor is turned off - as soon as the sensor in the eyepiece detects that you are looking through the viewfinder. However, if menu control is active, this does not happen until you tap the shutter release. You can also switch on the viewfinder with the function button, provided the latter is set accordingly (see next page).

### Brightness settings

▶ In the main menu, select




▶ Select



▶ Select **AUTO** in the submenu (for automatic setting controlled by the external brightness)

or

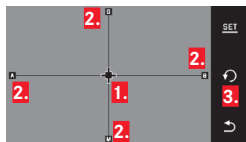
▶ Make the desired setting on the scale in the submenu using  or one of the setting dials

## Color settings Fig. 4.4

- ▶ In the main menu, select



- ▶ Select



1. Cursor for current setting
2. Color directions (Y = yellow, G = green, B = blue, M = magenta)
3. Symbol for resetting to neutral-position (center)

Fig. 4.4

- ▶ Use or the setting dials - vertical with the left, horizontal with the right - to move the cursor from its initial position in the center to the position that results in the desired color reproduction in the monitor/viewfinder image, i.e. towards the corresponding colors displayed at the edges
  - The color reproduction in the monitor/viewfinder image changes according to your setting.

## Setting the function button to switch the viewfinder on permanently

- ▶ In the main menu, select



- ▶ In , select



### Note:

With this function active, pressing the function button results in the monitor image never appearing, i.e. regardless of whether or not you are looking through the viewfinder. Pressing the function button again reactivates automatic switching between viewfinder and monitor.

### Automatic monitor shutdown

This function enables you to select the time after which the monitor is shut down or whether you want it to remain turned on. Shutting down saves power and also ensures that the camera is ready to use more quickly when reactivated.

- ▶ In the main menu, select



- ▶ Select the required setting in



## BASIC PICTURE SETTINGS

### File format/compression rate

The JPEG format **JPG** and the standardized raw data format **DNG** (= digital negative) are available. They can be utilized both separately and simultaneously.

▶ In the main menu, select



▶ Select the required setting in



### DNG compression

With the **DNG** format, you can select either uncompressed, or, in order to reduce file sizes, totally lossless compressed recording.

▶ In the main menu, select



▶ Select the required setting in



#### Note:

The indicated remaining number of pictures or recording time are an approximation, as the file size for compressed images can vary considerably depending on the subject of the photograph.

### JPEG resolution

When the **JPG** format is selected, pictures can be taken with 3 different resolutions (numbers of pixels). The settings available are **6M**, **12M** and **24M** (M = megapixels). This allows you to adjust the setting precisely to the intended use or to the available memory card capacity.

▶ In the main menu, select



▶ Select the required setting in



#### Note:

The **DNG** format is always stored at the maximum resolution regardless of the **JPG** settings.



## White balance

In digital photography, white balance ensures neutral, i.e. natural, reproduction of color in any light. It is based on the camera being preset to reproduce a particular color as white.




You can choose between automatic white balance, various presets, two fixed settings based on selective measurements, and direct setting of the color temperature.

1. **Automatic** (automatic settings)
2. **Daylight** (for outdoor pictures in sunshine)
3. **Cloudy** (for outdoor pictures in cloudy conditions)
4. **Shadow** (for outdoor pictures with the main subject in shadow)
5. **Tungsten** (for incandescent bulb lighting)
6. **Flash** (for illumination with electronic flash)
7. **Grey card 1** (memory slot for your own measured results)
8. **Grey card 2** (memory slot for your own measured results)
9. **Color temp.** (memory slot for fixed setting)

### Fixed presets

- ▶ In the main menu, select 
- ▶ Select 
- ▶ Select the required setting in the 1st submenu




### Manual setting by metering

- ▶ In the main menu, select 
- ▶ Select 
- ▶ In the 1st submenu, select  next to **Greycard 1** or **Greycard 2**
  - A yellow frame appears in the center of the monitor with an instruction below it.
- ▶ Aim the frame at a uniform white or gray object that completely fills the frame
- ▶ Touch **SET** to confirm

The camera releases the shutter and carries out metering and storage.

The settings can subsequently be retrieved using **Grey card 1** or **Grey card 2**.

### Direct color temperature setting

- ▶ In the main menu, select 
- ▶ Select 
- ▶ In the 1st submenu, select  next to **Color temp.**
- ▶ Select the required value in the 2nd submenu

### Selecting white balance functions with the left adjusting dial.

If the **WB** function is assigned to the left adjusting dial, it can be used to directly select the required option.

## ISO sensitivity

The ISO setting specifies the possible shutter speed and aperture combinations at a particular brightness. Higher sensitivities allow faster shutter speeds and/or smaller apertures (for "freezing" rapid movements or to increase the depth of field), although this can also result in greater noise.

- ▶ In the main menu, select 

- ▶ Select 

- ▶ Select the desired setting in the submenu (i.e. **AUTO ISO** for the automatic setting, or one of the eight fixed settings)

If the **ISO** function is assigned to the left setting dial, it can be used to directly select the required option.

Within the **AUTO ISO** option it is possible to limit the sensitivity range to be used (e.g. to control noise), and the slowest shutter speed to be used can also be specified (e.g. to prevent blurred pictures of moving subjects):

- ▶ In the main menu, select 

- ▶ Select 

- ▶ Select the **Max. exposure time** and/or **Maximum ISO** submenu
- ▶ Select the required settings in the **Max. exposure time** and/or **Maximum ISO** submenus

## JPEG image properties (Film Mode)

One of the many advantages of digital photography is that it is very easy to change critical properties of a picture.

On the Leica TL2, you can influence color reproduction, contrast, sharpness and color saturation before taking the picture.

### Note:

The functions and settings described in the next two sections relate exclusively to pictures in the **JPG** format. If the **DNG** file format is specified, these settings have no effect as in this case the image data is always saved in its original format.

## Color Rendering

For the color reproduction, you can select between **Standard**, **Vivid** – for highly saturated colors – and **Natural** – for slightly less saturated colors and a somewhat softer contrast. There are also two black and white settings **B&W Natural** (natural) and **B&W High Contrast** (high contrast).

- ▶ In the main menu, select 

- ▶ Select 

- ▶ Select the required setting in the submenu



### Contrast, sharpness, saturation

For each color reproduction setting, these 3 image properties can also be changed.


- The contrast, i.e. the difference between light and dark sections of the image, determines whether it has a more “flat” or “brilliant” effect. As a consequence, the contrast can be influenced by increasing or reducing this difference, i.e. by lighter reproduction of light sections of the image and darker reproduction of dark sections.
- Focus display – at least of the main subject – using the correct focusing is a prerequisite for a successful picture. In addition, the impression of sharpness of a picture is determined by the edge sharpness, i.e. how small the transition area between light and dark is at edges in the picture. The impression of being in focus can thus be changed by expanding or reducing these areas.
- When shooting in color, saturation determines whether the colors in the picture tend to appear as “pale” and pastel-like or “bright” and colorful.

▶ In the main menu, select



▶ Select



- ▶ In the 1st submenu, press **▶** for the required color reproduction
- ▶ In the 2nd submenu **Fig. 45**, use  to adjust the relevant image property, or make the desired setting using the right setting dial



**Fig. 45**

▶ Touch **SET** to confirm

- Whenever such a setting has been performed, the relevant color reproduction option is marked in the 1st submenu by an additional asterisk, e.g. **Standard\***.

## ADDITIONAL PICTURE SETTINGS

### Image stabilization

When using Leica SL lenses featuring OIS, your Leica TL2 lets you take advantage of these lenses' built-in stabilization function. By doing so, you can often achieve sharp pictures at shutter speeds that would otherwise be too slow.

▶ In the main menu, select



▶ Select the required setting in



#### Notes:

- When using Leica TL lenses, this function is not available, the respective tile is therefore not accessible, i.e. 'grayed out'.
- For further information about OIS, see the respective lens' instructions.

### Self-Timer


You can use the self-timer to take a picture with a delay of either 2 or 12 s. This is particularly useful for group photographs, where you want to appear in the picture yourself or if you want to avoid the picture being out of focus due to camera shake when releasing the shutter. We recommend that the camera is placed on a tripod. Additionally, you can select whether the self-timer operates only once or for several pictures (**Permanent** options).

▶ In the main menu, select



▶ Select the required setting in



If the  function is assigned to the left setting dial, it can be used to directly select the desired option (see p. 138).

- If the self-timer is turned on , , , or  is displayed.

#### Operation:

- ▶ Press the shutter release all the way down to take the picture
- The progress is indicated by the flashing self-timer LED:
  - 12 s delay time: slowly at first, faster for the last 2 s
  - 2 s delay time: As described above for the last 2 s
- The remaining time is counted down in the monitor.





#### Notes:

- A delay time in progress can be restarted at any time by pressing the shutter button again. The only way to cancel a delay time in progress though is to turn off the camera.
- When one of the **Permanent** options is selected, the function will remain active even after switching the camera off and back on.
- It is only ever possible to take single pictures when the self-timer is active, i.e. picture series and automatic bracketing cannot be combined with self-timer mode.
- In self-timer mode, the focus and exposure are not set when the shutter button reaches its pressure point, but immediately before the picture is taken.

## Recording the location with GPS

The external LEICA Visoflex (Typ 020) available as an accessory contains a GPS (Global Positioning System) receiver. If the viewfinder is attached, this enables the camera to add the location coordinates to the picture data.

### Setting the function

- ▶ In the main menu, select 
- ▶ Select the required setting in 
  - The "satellite" symbol in the monitor indicates the relevant status:
    - GPS off: No display
    - GPS on, no reception: 
    - GPS on, reception: 

### Notes on the function:

- GPS positioning requires as clear a path as possible to at least 3 of the GPS satellites (up to 9 are available from any point on earth).
- Make sure that the viewfinder is not covered with your hand or any other item, particularly metal objects.

- It may not be possible to receive good signals from GPS satellites at the following locations or in the following situations. In such cases, positioning may not be possible at all, or may be incorrect:
  - in closed rooms
  - underground
  - under trees
  - in a moving vehicle
  - close to high buildings or in steep valleys
  - close to high voltage cables
  - in tunnels
  - close to 1.5 GHz mobile telephones

### Information for safe use:

Make sure the GPS function is deactivated on board an aircraft before takeoff or landing, in hospitals or in other locations where there are restrictions on wireless transmissions.

### Important (legal restrictions on use):

In certain countries or regions, the use of GPS and associated technologies may be restricted. Therefore, before traveling in other countries you should consult the relevant country's embassy or your travel agent.

## PICTURE MODE

### Picture series

The Leica TL2 can be used to take single pictures and series of pictures.

▶ In the main menu, select



▶ Select the required setting in



### Notes:

- Picture series are taken at a frequency of 7 fps, provided shutter speeds of  $\frac{1}{60}$  s and faster are used.
- Picture series are not possible when using the flash. If a flash function is activated, only one picture is taken.
- If picture series mode is set and the self-timer is used at the same time, only a single picture is taken.
- After a series of a maximum of 29 pictures, the shooting frequency slows down slightly. This is due to the time required to transfer the data from the buffer memory to the card/internal memory.
- Regardless of how many pictures are taken in a series, the last picture is always shown first when they are reviewed.

### Focusing

Your Leica TL2 allows automatic as well as manual focusing. There are two automatic modes - **AFs** (single autofocus) or **AFc** (continuous autofocus). In both, you can choose between options covering either the complete distance setting range, or only short distances, e.g. to speed up focusing for close-ups.

### Automatic focusing (AF/Automatic distance setting)

▶ In the main menu, select



▶ Select the desired setting in



If the **AF** function is assigned to the left setting dial, it can be used to directly select the required option - **AFs**/**AFc** or **MF**.

- The set function is displayed in the monitor.

The **AFs** mode should be used if you want to take photos of subjects that do not, or hardly, move at all. Focus on the area that is to be in focus by applying light pressure to the shutter button (first pressure point). If the subject moves between first tapping the shutter button and the exposure, the desired part of the picture may no longer be in focus. By contrast, the **AFc** mode should be used if you want to photograph moving subjects. Here, you also focus on the desired area using the first pressure point of the shutter button. While it is being held down to the first pressure point, the camera permanently focuses on the previously focussed area.

- A successful AF setting is displayed as follows:
  - The color of the rectangle changes to green
  - with multi-zone metering up to 9 green rectangles appear
  - an acoustic signal can be heard (if activated).

#### Notes:

- With the shutter button pressed halfway, it is also possible to manually change the automatically set distance in autofocus mode with the lens' distance setting ring.
- The setting is stored along with the exposure setting.
- In certain situations the AF system is unable to set the distance correctly, e.g. when:
  - The distance to the subject you are aiming at is outside the setting range of the attached lens, and/or
  - The subject is not sufficiently illuminated (see next section).
 These situations and subjects are indicated by:
  - Color of rectangle changes to red,
  - With multi-zone metering the display changes to a single red rectangle
- When using Leica M or R lenses with the Leica M or R Adapter L available as an accessory, only manual focusing is possible.
- Depending on the Leica TL lens attached, the **FOCUS MODE** point is supplemented by the measuring methods **AFs Macro** and **AFc Macro**.

#### Important:

The shutter release button is not locked, regardless of whether or not the focusing is correct for the relevant subject.

#### AF auxiliary light

The built-in AF auxiliary light extends the operating range of the AF system in poor lighting conditions. If the function is active, this light comes on as soon as the shutter button is pressed.

- ▶ In the main menu, select



- ▶ Select the required setting in



#### Note:

The AF auxiliary light illuminates a range of approximately 4 m. AF mode is therefore not available at distances beyond this limit.

## Autofocus metering methods/Operating modes

For optimum adjustment of the AF system to different subjects, situations and your compositional ideas, you can choose between five AF metering methods on the Leica TL2.

- ▶ In the main menu, select



- ▶ Select



- ▶ Select the required setting in the submenu

### Spot/single point measurement

Both metering methods detect only those parts of the subject within the relevant AF frame.

- The metering zones are indicated by a small AF frame. The very small metering zone for spot measurement allows focusing on tiny details of the subject.

The slightly longer single point metering zone is less critical when focusing, and therefore easier to handle while still allowing selective measuring.

The AF function can also be used for picture series in which the part of the subject you want to be in focus is always at the same off-center point in the image.

With both metering methods, you can do this by moving the AF frame, which is otherwise positioned in the center of the monitor screen, to another point. This can be done using menu control or directly.

### Direct operation Fig. 46 a-c

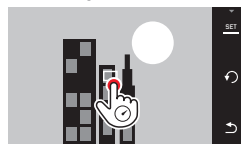


Fig. 46 a

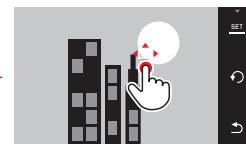


Fig. 46 b

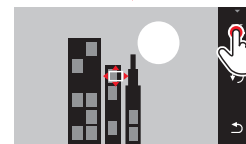


Fig. 46 c

### Operation after selecting function from menu Fig. 47 a-c, d/e

Fig. 47 a-c, d/e

- ▶ In the main menu, select



- ▶ In the 1st submenu, press  for the required metering method 

The metering zone can then be shifted or moved in two ways.



Fig. 47 a



Fig. 47 b

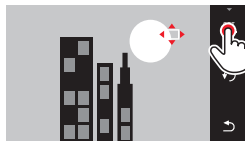


Fig. 47 c



Fig. 47 d



Fig. 47 e

The frame can be reset directly to the center position before confirming [Fig. 48 a/b](#).

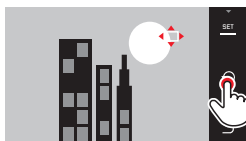


Fig. 48 a



Fig. 48 b

### Note:

In both cases, the metering zones remain at the last positions set even if the metering method is changed or the camera is turned off.

### Taking photographs

1. Aim the AF frame at the desired subject or move it there accordingly
  - The metering system locks on to the registered subject.
2. Press the shutter button to the first pressure point
  - The AF frame 'follows' the locked subject.
3. Keep the shutter button half-pressed until you take the picture
  - The AF frame 'follows' the locked subject.
4. Push the shutter button all the way down to take the picture

### Notes:

- Tracking works regardless of which AF mode (**AFs/AFc**) is selected.
- Tracking stops when you let the shutter button go. In this case the metering zone will remain at the last position reached.

## Touch AF/Touch AF + Shutter release

In this mode, the AF frame can be moved for every picture, without additional settings in the menu. The metering characteristics and metering zone size correspond to single point metering.

- ▶ In the main menu, select



- ▶ Select



- ▶ Select **Touch AF** or **Touch AF + Release** in the submenu

### Moving the metering zone [Fig. 49 a/b](#)

- ▶ Touch the monitor at the required position in the image field



[Fig. 49 a](#)



[Fig. 49 b](#)

- The AF frame 'jumps' to the selected position.

## Pictures

In this case, the focusing process does not start when the shutter button is pressed to the 1st pressure point but immediately when you touch the monitor. In addition, the **Touch AF + Release** function can be used to focus and automatically take a picture with just one touch.

### Note:

The metering zone remains at the last point determined, even after turning off the camera.



## Multi-zone metering

This metering method detects the subject using a total of 49 zones. Focusing is carried out automatically on the parts of the subject at the shortest distance, thus providing maximum reliability for snapshots. The zones used are indicated with AF frames.

- ▶ In the main menu, select 
- ▶ Select 
- ▶ Select **Multi Point** in the submenu

## Face detection

In this mode, your Leica TL2 automatically detects faces in the picture and focuses on the one at the shortest distance. If no faces are detected, multi-zone metering is used.

- ▶ In the main menu, select 
- ▶ Select 
- ▶ Select **Face Detection** in the submenu

## Manual focusing

For certain subjects and situations, it can be beneficial to set the focus yourself, rather than using autofocus. For example, if you are using the same setting for several pictures and it would be more work to use metering memory lock, or if you want to keep the setting at infinity for landscape pictures, or if you want to allow no or only a slower AF mode in poor, i.e. very dark, lighting conditions.

► In the main menu, select



► Select MF in



Manual focusing is carried out using the corresponding ring on the lens.

The optimum setting is reached when the monitor screen shows the key part(s) of your subject as you want them to appear.

### Note:

Manual focusing is - with the shutter button pressed down half-way  
- possible in autofocus mode as well.

## Auxiliary function for manual distance setting

To make it easier to make the setting and to increase accuracy, the Leica TL2 provides you with two useful tools.

- Marking of clearly focused subjects (focus peaking): Edges of sharply rendered subject parts are marked red, making it easy to identify the best setting.
- Enlarged display of a central section:  
Reason: The larger details of the subject appear in the monitor, the more accurately you can assess their sharpness and the more precisely you can focus.

The default setting is focus peaking on, but you can select the enlargement function instead, or choose to utilize both simultaneously.

## Selecting the function

► In the main menu, select



► Select the desired setting in



## Focusing Fig. 50 a/b

► Determine your trimming

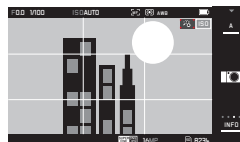


Fig. 50 a

- ▶ Rotate the lens' focusing ring
  - All sharply rendered subject detail edges are marked in red. This happens according to the principle maximum contrast = sharp. Alternatively or additionally (see previous page), the monitor image switches to a 3x magnification mode. Also, a display appears indicating both the present (marked in white) and the second available magnification factor. Touching the unmarked factor leads to a 6x magnification, or switches between the two. The enlargement level that appears first is always the last one used. Approx. 5 s after the focusing ring was turned the last time, the camera automatically switches back to the original monitor image. This can also be initialized at any time by pressing the shutter button to the 1st pressure point.
- ▶ Set the correct focus for the desired subject parts



Fig. 50 B

- 1  $x3$ -/ $x6$  displays for changing enlargement
- 2 Distance scale, the bar indicates the current setting (only appears in conjunction with the status displays, see 'INFO displays')

**Notes:**

- Focus peaking is based on subject contrast, i.e. differences between bright and dark.
- If you are using the Leica M- or R-Adapter L, the left setting dial assignment changes to **FOCUS AID**  $x3$ ,  $x6$  or **Off**.
- In autofocus mode, too, the automatically set distance can be altered manually with the distance setting ring when the shutter release is pressed halfway.

## EXPOSURE METERING AND CONTROL

### Exposure Metering Methods

Your Leica TL2 offers three exposure metering methods to adapt to prevalent lighting and other conditions like your working methods or compositional ideas:

▶ In the main menu, select



▶ Select the required setting in



### Multiple field metering -

With this metering method, the camera automatically analyses the brightness differences in the subject and, by comparing them with programmed brightness distribution patterns, arrives at the likely position of the main subject and the corresponding best exposure. As a result, this method is particularly suitable for spontaneous, uncomplicated, and yet reliable photography, even under difficult conditions and therefore for the cameras automatic program mode.

### Center-weighted metering -

This metering method allocates the highest weighting to the center of the image field, but also records all other areas. Particularly when used in conjunction with metering memory lock, it allows the exposure to be selectively adjusted to specific sections of the subject, while simultaneously taking into account the entire image field.

### Spot metering -

This metering method is concentrated exclusively on a small area in the center of the image. It allows exact measurement of small or tiny details for precise exposure – preferably in conjunction with manual setting.

For backlit pictures, for example, you normally need to prevent the brighter surroundings causing underexposure of the main subject. The much smaller metering field with spot metering enables these subject details to be selectively evaluated.

### Exposure control

Your Leica TL2 offers four exposure modes for optimized adjustment to the relevant subject or your preferred working method.

#### Notes:

- Depending on the prevailing light conditions, the brightness of the monitor image can differ from that of the actual pictures taken. Particularly for long exposures on dark subjects, the monitor image appears considerably darker than the – correctly exposed – picture.
- When using Leica M or R lenses with the Leica M Adapter L or the Leica R Adapter L (available as accessories), only aperture priority and manual setting are available, i.e. the automatic program (P), shutter speed priority (S) and the scene modes are not available. If one of these modes is selected, the camera automatically switches to aperture priority mode when the adapter is attached. The mode displayed in the monitor also changes to A. The aperture value displayed is F0.0.

## Program mode - P

For fast, fully automatic photography. The exposure is controlled by an automatic shutter speed and aperture setting.

### Setting the mode

- ▶ Open the exposure mode/scene mode menu

- ▶ Select



### Taking a picture

- ▶ Press the shutter button to the 1st pressure point
  - Both the shutter speed and aperture value are displayed in white.  
If even a completely open or closed aperture combined with the fastest or slowest shutter speed will result in under- or overexposure, both values are displayed in red.

If the automatically calculated pair of values appears to be appropriate for the intended composition:

- ▶ Press the shutter button all the way down to take the picture

## Changing the specified shutter speed/aperture combinations (Shift)

Changing the preset values using the Shift function combines the reliability and speed of fully automatic exposure control with the opportunity to vary the speed/aperture combination selected by the camera at any time to fit in with your own ideas and intentions.

- ▶ This is done using the right setting dial. If you prefer to use faster speeds, e.g. for sports shots, turn it to the left. On the other hand, if you prefer a larger depth of field, for landscape shots for example, and are prepared to accept the resulting slower shutter speeds, turn it to the right.

The overall exposure, i.e. the brightness of the image, remains unchanged. The adjustment range is limited to guarantee correct exposure.

- Shifted pairs of values are indicated by a + next to the shutter speed.

To prevent accidental use, the values revert to the default settings after each picture, and also when exposure metering is automatically deactivated after 12 s.

## Aperture priority - A

Aperture priority mode sets the exposure automatically according to the manually selected aperture. It is particularly suitable for pictures where the depth of field is a critical compositional element.

By selecting an appropriately low aperture value, you can reduce the depth of field range, for example in a portrait to "isolate" the face which is in focus from an unimportant or distracting background, or conversely you can use a higher aperture value to increase the depth of field range, so that everything from the foreground to the background will be sharp in a landscape shot.

### Setting the mode

- ▶ Open the exposure mode/scene mode menu

- ▶ Select



### Taking a picture

- ▶ Select the required aperture value with the right setting dial,
- ▶ Press the shutter button to the 1st pressure point
  - Both the set aperture value and the automatically calculated shutter speed are displayed in white.  
If even the fastest or slowest shutter speed combined with the set aperture will result in under- or overexposure, both values are displayed in red.

If the automatically calculated shutter speed appears appropriate for the intended composition:

- ▶ Press the shutter button all the way down to take the picture

## Shutter speed priority - S

Shutter speed priority mode sets the exposure automatically according to the manually selected shutter speed. It is therefore particularly suitable for pictures of moving subjects, where the sharpness of the movement depicted is a critical compositional element.

An appropriately fast shutter speed will avoid undesirable blurring of the movement, i.e. "freeze" your subject or you can use a slower shutter speed to express the dynamic nature of the movement with a deliberate "blur effect".

### Setting the mode

- ▶ Open the exposure mode/scene mode menu

- ▶ Select



### Taking a picture

- ▶ Select the required shutter speed with the right setting dial,
- ▶ Press the shutter button to the 1st pressure point
  - Both the set shutter speed and the automatically calculated aperture value are displayed in white.  
If even the lowest or highest aperture value combined with the set shutter speed will result in under- or overexposure, both values are displayed in red.

If the automatically calculated aperture value appears to be appropriate for the intended composition:

- ▶ Press the shutter button all the way down to take the picture

## Manual setting - M

If, for example, you want to achieve a particular effect that is only possible with a very specific exposure, or if you want to ensure that several pictures with different trimming have an absolutely identical exposure, then you can set the shutter speed and aperture manually.

### Setting the mode

- ▶ Open the exposure mode/scene mode menu

- ▶ Select 

### Taking a picture

- ▶ Select the required aperture value with the left setting dial,
- ▶ Select the required shutter speed with the right setting dial
- ▶ Press the shutter button to the 1st pressure point
  - Both the shutter speed and aperture value are displayed in white.  
The light balance scale also appears. It covers a range of  $\pm 3EV$  (exposure value) in  $\frac{1}{3}EV$  increments.  
Settings within  $\pm 3EV$  are indicated by white lines on the scale, settings outside this range by red lines.
- ▶ Adjust the settings for correct exposure so that the central mark is displayed in white.

If the set values and/or the exposure appears to be appropriate for the intended composition:

- ▶ Press the shutter button all the way down to take the picture

### Note:

The monitor image displays an exposure simulation for manual setting.



## Histogram and clipping displays

The Leica TL2 provides you with two displays that make it easy to determine not only a correct exposure, but also to create a picture with the desired rendition. Together, they allow quick and easy assessment of the exposure setting.

### Histogram

The histogram depicts the brightness distribution in the picture. The horizontal axis shows the brightness values from black (left) through gray to white (right). The vertical axis corresponds to the number of pixels at each brightness level. This form of representation – in conjunction with the impression of the picture itself – provides an additional quick and easy assessment of the exposure setting. The histogram is available in both picture and review mode.

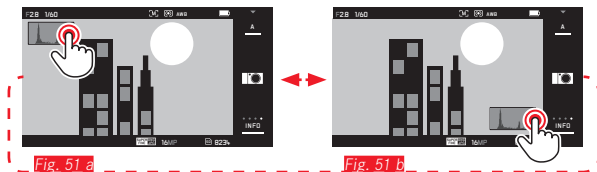
**For picture mode** [see p. 24 Fig. 21d](#)

▶ **INFO** 3x 



**For review mode** [see p. 24 Fig. 22 b/c](#)

▶ **INFO** 2x 

The histogram can also be moved to the bottom right corner of the monitor screen [Fig. 51 a/t.](#)



In addition to the black&white histogram, in review mode you also have the option of an RGB histogram, in which the brightness values for the three colors red, green, and blue are represented separately:

- ▶ In the main menu, select 
- ▶ Select  the required setting in

## Clipping

In review mode, the flashing red clipping display indicates ‘blown out’, i.e. overexposed parts of a picture. Thus, it serves as a very simple and precise instrument for selecting and adjusting the exposure setting.




see p. 130 [Fig. 22.6](#)

### Notes on the histogram and clipping displays:

- For a picture with flash, the picture histogram cannot represent the final exposure as the flash is fired after the display.
- In picture mode, the histogram should be regarded as a “trend indicator” and not as a depiction of the exact numbers of pixels.
- The histograms when reviewing and taking a picture may differ slightly from one another.
- The histogram and clipping displays always refer to the currently shown picture section.
- The review histogram and the clipping display are available when showing the complete picture as well as just a section, but not in the case of simultaneous display of 9 reduced pictures.
- The clipping display is not available for videos.

## Scene modes

The Leica TL2 provides nine "advanced" automatic program options for exceptionally easy and reliable photography. The tenth option

-  - is an automatic snapshot setting for general use.

The other nine are designed for the specific requirements of frequently occurring subject types.

In all cases, a range of additional functions are automatically controlled in addition to the shutter speed and aperture.

## Setting the mode

▶ Open the exposure mode/scene mode menu

▶  Select

▶ Select the required scene mode

## Taking a picture

As in automatic program mode

## Notes:

- The Program Shift function is not available.
- The two setting dials have no function.

## Metering memory lock

For composition reasons, it can be beneficial not to have the main subject in the center of the picture.

In these cases, metering memory lock - in exposure modes **P**, **S** and **A**, and single zone and spot metering AF modes and focusing by touch - allows you to first take a reading for the main subject and then retain the relevant settings until you have selected your final trimming and are ready to take the picture.

### Taking a picture with this function:

- ▶ Aim the relevant AF frame at the part of your subject you want to adjust the sharpness and exposure to.
- ▶ Press the shutter button to the first pressure point to set and store the sharpness and exposure.
- ▶ Keep the shutter button half-pressed and move the camera to set your final trimming.
- ▶ Press the shutter button all the way down to take the picture

## Exposure compensation


Some subjects consist predominantly of areas of above or below average brightness, for example extensive areas of snow or, conversely, a full-format black steam locomotive. In **P**, **S**, and **A** exposure modes, it may be more useful in such cases to set an appropriate exposure compensation instead of using metering memory lock for each picture. The same applies if you want to ensure an identical exposure for several pictures. Values of + 3 to - 3EV are available in  $\frac{1}{3}$  EV increments.

- ▶ In the main menu, select



- ▶ Select



- ▶ In the submenu, make the desired setting on the scale using  or one of the setting dials
- ▶ Press **SET** to confirm

If the **EV** function is assigned to the **left** setting dial, it can be used to directly select the compensation value.





- If a compensation value is set, it is displayed in the monitor, e.g. **EV+3**. During setting, you can observe the effect on the monitor image, which gets darker or lighter.

### Notes:




- When setting the exposure manually, exposure compensation is only possible using the menu.
- A set exposure compensation remains active even after any number of pictures and even after turning off the camera, until it is reset to  $\pm 0$  (= center of scale).

## Automatic exposure bracketing

High contrast subjects that have both very bright and very dark areas can have very different effects depending on exposure. The automatic bracketing function enables you to take a series of three pictures with graduated exposure. You can then select the best picture for further use.

- ▶ In the main menu, select  EXPOSURE
- ▶ Select  ±0
- ▶ In the submenu, make the desired setting on the scale using  or one of the setting dials
- ▶ Press **SET** to confirm
  - If bracketing is set, this is indicated by  in the monitor. While the three pictures are being taken, you can observe the effect as the monitor screen becomes darker or lighter accordingly.

## Notes:

- Depending on the exposure mode, the graduations are produced by changing the shutter speed (/A/M) or the aperture (.
- The sequence of the pictures is: correct exposure/underexposure/overexposure.
- Depending on the available shutter speed/aperture combination, the working range for automatic bracketing may be limited.
- Once set, bracketing remains active even after any number of releases and even after turning off the camera, i.e. until it is reset to  (= center of scale).

## FLASH PHOTOGRAPHY

### COMPATIBLE FLASH UNITS

The following flash units enable TTL flash metering and, depending on their feature set, a varying number of the functions described in these instructions.

- The Leica system flash units SF 40, SF 64, and SF 58.
- Other Leica system flash units, except the Leica SF 20.

Other commercially available flash attachments with standard flash foot and positive center contact, and fired by the<sup>center</sup> contact (X contact) can also be used. We recommend the use of modern thyristor-controlled electronic flash units.

### ATTACHING A FLASH UNIT

- ▶ Turn off the camera and the flash unit.
- ▶ Slide back the cover that protects the accessory shoe on the camera when not in use.
- ▶ When attaching, make sure that the flash unit's foot is fully inserted into the accessory shoe and, if available, secured against falling out with the clamping nut. This is important because changes of position in the accessory shoe can break the required contacts, causing malfunctions.

The flash unit should be set to **TTL** mode to allow automatic control by the camera. When set to **A**, above- or below-average brightness subjects may not be exposed correctly.

When set to **M**, the flash exposure must be controlled by manually setting a flash output level appropriate for the aperture and shutter speed settings determined by the camera.

- The display for the set flash mode appears in white (see next pages). The flash mode will blink red if the flash unit is not fully charged and therefore not ready.

The camera determines the correct flash output by firing one or more pre-flashes fractions of a second before the actual exposure. Immediately afterwards, i.e. during the exposure, the main flash is fired. All parameters that influence the exposure (e.g. filters, changed aperture settings) are automatically taken into account.

#### Notes:

- The flash unit must be ready to flash, otherwise faulty exposures may result and the camera may generate an error message.
- Serial exposures and automatic bracketing with flash are not available. In these cases, even if a flash unit is attached and switched on, a flash mode display will not appear and no flash will be fired.
- Simultaneous use of a flash unit and the Leica Visoflex electronic viewfinder is not possible.

<sup>1</sup>However, if flash units not specially designed for the camera are used that do not automatically set the white balance on the camera, the **Flash** setting should be used (see p. 145).

## FLASH MODES

### Selecting the mode:


▶ In the main menu, select



▶ Select



- ▶ Select the required setting in the submenu
- The flash mode display changes accordingly.

If the  function is assigned to the left setting dial, it can be used to directly select the required option.

- The set mode is displayed in the monitor.

### Note:

If no system compatible flash unit is attached, this setting is not available and the function therefore grayed out.

### Automatic flash activation

This is the default mode. An attached and switched on flash unit is fired automatically whenever slower shutter speeds could lead to blurred pictures in poor lighting conditions.

### Automatic flash and pre-flash activation

To reduce the "red eye" effect in photographs of people with flash. If possible, the people should not look directly at the camera. As the effect is exacerbated when the pupils are wide open in low light conditions, you should turn on as much room lighting as possible when taking photographs indoors, for example. The pre-flash, which is fired shortly before the main flash when you press the shutter button, narrows the pupils of people looking at the camera thereby reducing the effect.

### Manual flash activation

For backlit pictures, in which your main subject does not fill the entire frame and is in shadow, or in situations where you want to moderate high contrasts (e.g. in direct sunlight) (fill in flash). As long as this mode is activated, an attached and switched on flash unit will fire each time you take a shot, whatever the prevailing lighting conditions. The flash power depends on the metered ambient brightness: in poor light it is the same as in automatic mode, with a reduced power as the brightness increases. The flash then works as a fill-in light, e.g. to light up dark shadows in the foreground or backlit subjects and in order to create more balanced overall lighting.

### Manual flash and pre-flash activation

For a combination of the situations and functions described above.

### Automatic flash activation with slower shutter speeds

For simultaneous and more appropriate, i.e. brighter, rendition of dark backgrounds and for fill-in flash for the foreground.

Explanation: To minimize the risk of blurring, the shutter speed is not extended beyond  $\frac{1}{30}$  s in the other flash modes. This is why in flash shots, objects in the background not illuminated by the flash are often badly underexposed.

To take adequate account of the available ambient light, the slower shutter speeds required in such situations (up to 30 s) are allowed in this mode.




#### Notes:

- Depending on the **AUTO ISO SETTINGS** (see p. 146) , it is possible that the camera will not support slower shutter speeds as in such cases increasing the ISO sensitivity takes priority.
- The desired slowest shutter speed can be set in the **Slowest Speed** (see p. 146) item.

### Automatic flash and pre-flash activation with slower shutter speeds

For a combination of the situations and functions described above.

#### Note:

To prevent blurred pictures with the slower shutter speeds in , and   modes, you should hold the camera steady, i.e. rest it on something or use a tripod. Alternatively, you can select a higher sensitivity.

#### Flash range

The usable flash range depends on the aperture and sensitivity values set manually or calculated by the camera. To ensure that the flash light provides sufficient illumination, it is essential that the main subject is within the relevant flash range.



## Synchronization time point

Flash photographs are always illuminated by two light sources, the available light and the light from the flash. The time at which the flash is fired normally determines where the parts of the subject illuminated exclusively or predominantly by the flash are shown in the frame.

The conventional flash firing point at the beginning of the exposure can lead to apparent contradictions, e.g. a vehicle being “overtaken” by the light trail from its own tail lights.

Your Leica TL2 allows you to choose between this conventional flash firing point and the end of the exposure:

▶ In the main menu, select



▶ Select the required setting in



In the example cited, the light trail from the tail lights then follows the vehicle as expected. This flash technique gives a more natural impression of movement and dynamics.

### Note:

When using the flash with faster shutter speeds, in terms of the image there is no difference, or only a difference for rapid movements between the two flash firing points.

## Flash exposure compensation

This function can be used to selectively reduce or strengthen the flash exposure regardless of the exposure from available light, e.g. in a picture taken in the evening, to lighten the face of a person in the foreground while retaining the lighting atmosphere.

▶ In the main menu, select



▶ Select



▶ In the submenu, make the desired setting on the scale using



or one of the setting dials

▶ Touch **SET** to confirm

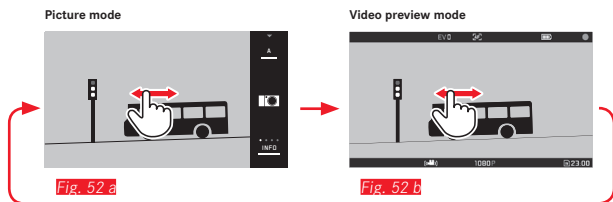
- If a compensation is set, this is indicated by  $\pm$  in the monitor.

### Notes:

- Flash exposure compensation changes the range of the flash unit.
- Once set, compensation remains active even after any number of pictures and even after turning off the camera, until it is reset to  $\pm 0$  (= center of scale).
- Compensation values set in the camera's menu system are not effective as soon as one is set on an attached and accordingly featured flash unit such as the Leica SF64.

## VIDEO RECORDING

You can also use the Leica TL2 to make video recordings. Switching between picture and video preview modes is possible via gesture control [Fig. 52 a/b](#).



### Notes:

- As only part of the sensor surface is used, the effective focal length is increased in each case, i.e. the field of view becomes correspondingly smaller.
- Uninterrupted video recordings are possible up to a maximum length of 7/29 minutes (4K/all other resolutions). The maximum file size is 4 GB. If a recording exceeds this limit, the respective part is automatically stored in another file (a.s.o.).

For video recordings, the following functions are available:

### Resolution

- ▶ In the main menu, select  MOTION IMAGE
- ▶ Select the desired setting in , i.e. either **4K**, or **1080p** for 'full-HD' recording, or **720p** for 'HD' recording, or **SLOMO** for slow motion recording

### Note:

For **4K** video recording, memory cards with fast read/write speeds should be used, preferably with at least Class U3 and/or V30 standard. Using slower cards may result in the recording being aborted immediately after reaching the internal buffer capacity limit.

### ISO sensitivity

All settings available in the menu.

### Distance setting:

All options described on pages 150-156.

### Exposure Metering Methods

All options described on page 158

### Exposure control

This is totally independent of the exposure mode and the shutter speed and aperture settings made for photos.

- **Shutter speed:** Depending on the selected resolution
- **Aperture:** Automatic (automatic settings)
- If correct exposure is not possible even with the maximum aperture, the ISO sensitivity is automatically increased - regardless of any manual setting.



### Note:

The automatic exposure control takes all brightness fluctuations into consideration. If you do not want this, e.g. for landscape pictures and pan shots, you should set the shutter speed manually.

### Film presets, contrast, sharpness, color saturation:

All options described on pages 146 but in this case only the white balance, contrast, saturation, and sharpness settings are changed.

### Stabilization




- ▶ In the main menu, select 
- ▶ Select the required setting in 

### Note:

When using video stabilization, the trimming is slightly reduced compared to operation without stabilization.

### Starting/ending the recording

In the default setting, the function button serves as video release. If, on the other hand, one of the other optional functions is assigned to this button, two possible procedures are available: To utilize the function button as video release, it must be reset accordingly.

- ▶ In the main menu, select 
- ▶ In , select 

If you prefer not to change the existing function button setting, you can utilize the shutter button as an alternative after calling up the video screen with gesture control.

### Starting:

- ▶ Press the function/shutter button
  - A video recording in progress is indicated by a flashing red dot. The remaining recording time is also displayed.



### Ending:

- ▶ Press the function/shutter button again

### Sound recording

Sound is recorded in stereo with the built-in microphones.

To reduce any noise caused by wind during sound recording, a damping function is available:

- ▶ In the main menu, select 
- ▶ Select the required setting in 

### Note:

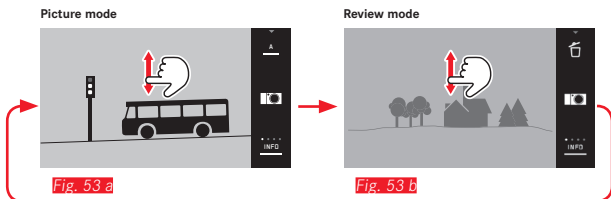
Both autofocus and changing the focal length on zoom lenses produce noises that may be picked up in the recording. To prevent this, you should not use either of these functions while recording is in progress - only adjust the focus manually and do not change the focal length.

## REVIEW MODE

### Continuous review mode

Switching between picture and continuous review modes can be performed in two ways.

#### With gesture control [Fig. 53 a/b](#)



#### Using the function button

In the default setting, the function button serves as video release. To use it to switch between picture and review modes, it must be reset accordingly.

- ▶ In the main menu, select



- ▶ In , select



#### Notes:

- You can switch back from review mode to picture mode at any time by tapping the shutter button.
- From the menu, you must select picture mode first before you can switch to review mode.
- In review mode you can select whether you want to view the pictures on the card or pictures saved in the internal memory.

- If the memory card or internal memory does not contain any image files, **No valid image to play** appears.
- If you have used the picture series function or automatic bracketing, the last or last saved picture in the series is displayed first - if not all pictures in the series have been overwritten by the camera's internal back-up memory yet.
- It may not be possible to view files that were not created on this camera.
- In some cases, the monitor image may not have the usual quality or the monitor will remain blank and only display the file name.

### Automatic review

You can automatically review every picture immediately after taking it with the **AUTO REVIEW** function.

- ▶ In the main menu, select



- ▶ Select



- ▶ Select the required function or duration in the **DURATION** submenu
- ▶ Select the desired setting in the **HISTOGRAM** submenu

#### Note:

Portrait format pictures displayed using **AUTO REVIEW** are initially shown with no rotation even if the **AUTO ROTATE** function is active. You can use to rotate the picture.

## VIEWING PICTURES IN PORTRAIT FORMAT

If the camera was held horizontally when taking the picture, the picture is also displayed this way. For portrait pictures, i.e. taken with the camera held vertically, this may not be practical when viewing with the camera held horizontally, if the monitor screen is not displayed as an upright picture.

► In the main menu, select



► Select



► Select the desired setting in the submenu

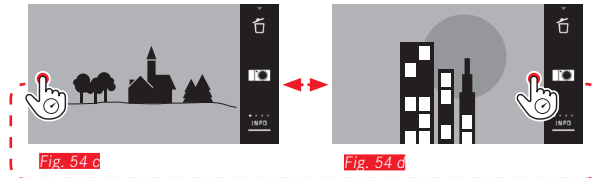
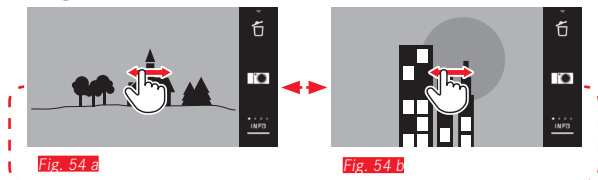
If **On** is selected, pictures in portrait format are automatically displayed upright.

### Notes:

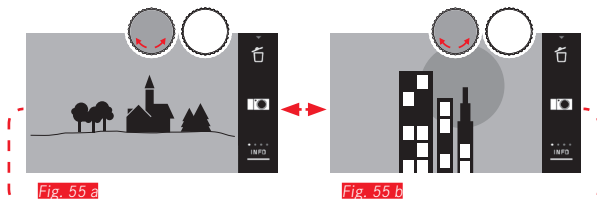
- Portrait format pictures displayed upright are necessarily significantly smaller.
- This function is not available with **AUTO REVIEW**.

## SELECTING PICTURES

With gesture control **Fig. 54 a/b-c/c**






With **left** setting dial **Fig. 55 a/b**



Swiping to the right or turning the setting dial to the right selects the pictures with higher numbers, swiping to the left or turning the setting dial to the left selects those with lower numbers. In each case, the pictures are displayed in an endless loop. When the last picture is reached, the first is displayed again.

## ENLARGING/REDUCING PICTURES

Being able to enlarge a picture being reviewed makes it possible to get a better idea of how in focus it is. Pictures can be enlarged and reduced using the  /  gestures [Fig. 56 a/b](#) or the [right](#) setting dial [Fig. 57 a/b](#). The  gesture gives you the maximum enlargement in two stages [Fig. 58 a-c](#).

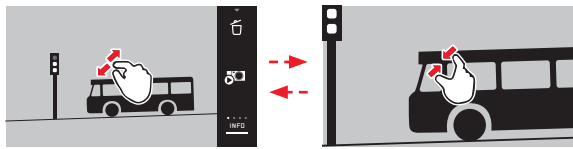


Fig. 56 a

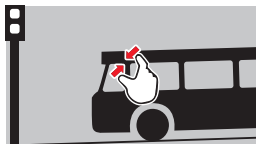


Fig. 56 b

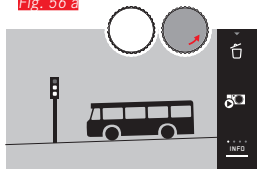


Fig. 57 a



Fig. 57 b



Fig. 58 a



Fig. 58 b

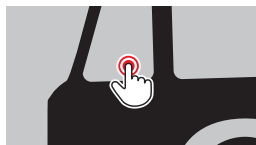


Fig. 58 c

### Note:

Touching the corresponding point on the monitor determines which part of the picture is enlarged.

### Simultaneous display of 9 pictures

Viewing 9 reduced pictures enables you to get an overview or to find the picture you are looking for more quickly [Fig. 59 a/b](#) / [Fig. 60 a/b](#).



Fig. 59 a



Fig. 59 b

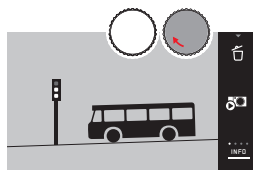


Fig. 60 a

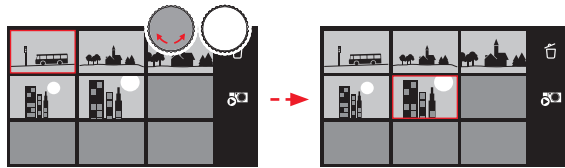


Fig. 60 b

### Notes:

- Enlarging cannot be performed on videos.
- In the enlarged/9 picture display, additional information cannot be called up.
- The more the picture is enlarged, the more the reproduction quality deteriorates – due to the proportionately lower resolution.
- It may not be possible to enlarge pictures taken using other camera types.

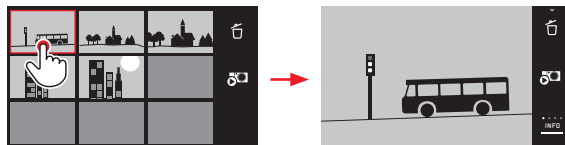
### Selecting a picture in the 9 picture view *Fig. 61 a/b*



*Fig. 61 a*

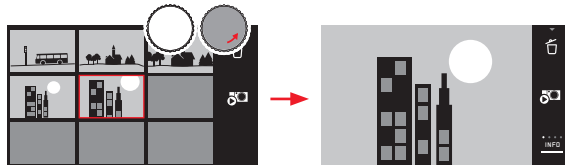
*Fig. 61 b*

### Exiting the 9 picture view *Fig. 62 a/b/ Fig. 63 a/b*



*Fig. 62 a*

*Fig. 62 b*

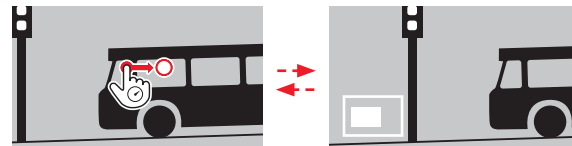


*Fig. 63 a*

*Fig. 63 b*

### SELECTING THE TRIMMING *Fig. 64 a/b*

In an enlarged picture, you can move the enlarged trimming away from the center, e.g. to check reproduction of subject details outside the center.



*Fig. 64 a*

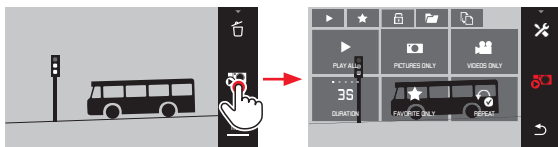
*Fig. 64 b*

- The approximate position of the detail in the picture is indicated.

## REVIEW MENU

The review menu contains a range of functions, which can be set using submenus.

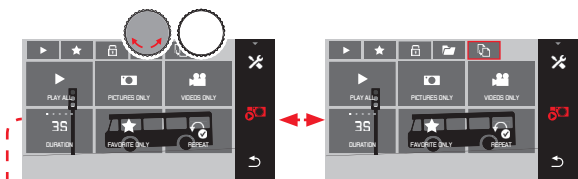
Opening the review menu [Fig. 65 a/b](#)



[Fig. 65 a](#)

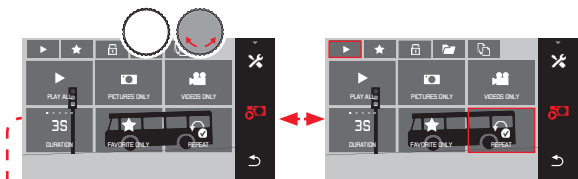
[Fig. 65 b](#)

As an alternative to the pure gesture control shown here and on the following pages, individual operations can also be carried out using the setting dials [Fig. 66 a/b](#) / [Fig. 67 a/b](#).



[Fig. 66 a](#)

[Fig. 66 b](#)



[Fig. 67 a](#)

[Fig. 67 b](#)

## Slide show

On the Leica TL2 you can make a setting so that pictures will automatically be shown in a sequence. Within this function, you can specify whether all the pictures are to be displayed, or only those marked as favorites. Or only photos, or only videos. In addition, you can select the time for which pictures will be displayed, and whether the slide show will be repeated until you cancel it. The slide show submenu appears when you open the review menu.

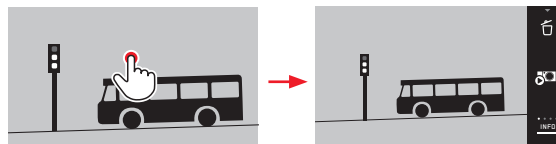
▶ The subsequent operations are carried out in the relevant submenus:

- Settings in and
- Start with, , , or

### Note:

Your settings in **DURATION** and **REPEAT** are retained even when you turn the camera off and back on.

Exiting the slide show [Fig. 68 a/b](#)



[Fig. 68 a](#)

[Fig. 68 b](#)





## Marking recordings as favorites/canceling markings

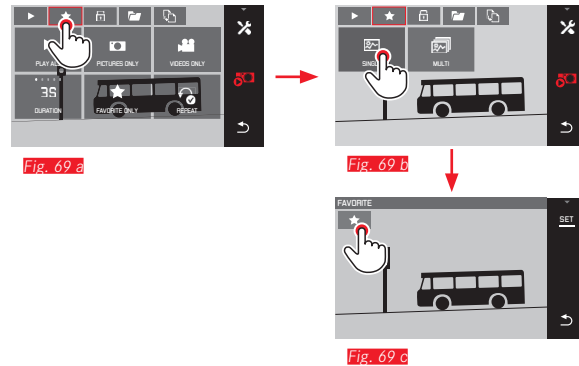
You can mark any recording as favorite, e.g. so you can find it more quickly.

## Protecting recordings/clearing delete protection

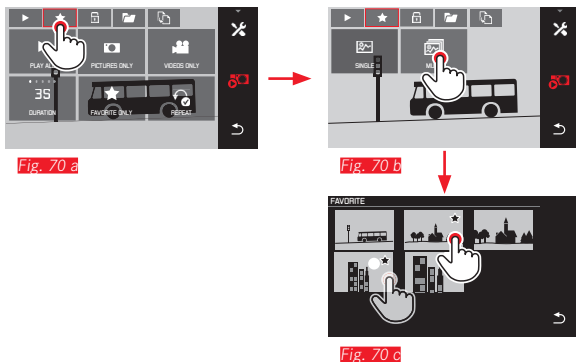
Recordings that you want to protect from accidentally being deleted can be marked.



The operations used to mark and protect are the same, the only difference is the way you enter the relevant submenus:  for favorites,  for protection. The operations are described here for favorites as an example.

## Marking individually **Fig. 69 a-c**



At the 3rd step, as an alternative to touching , marking can also be carried out by touching **SET**.

**Marking multiple** *Fig. 70 a-c***Deleting marking(s)**

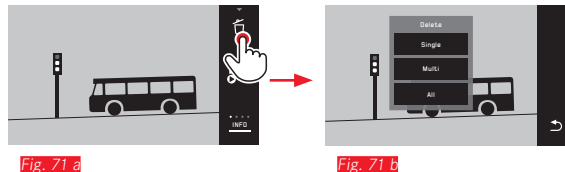
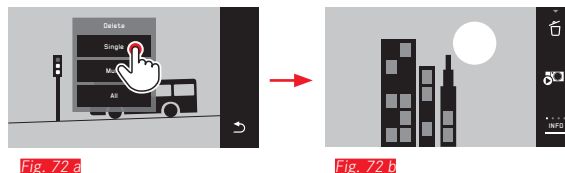
At the 3rd step, markings can be cleared by touching  or  again.

**Notes:**

- If you attempt to delete protected pictures, warning messages appear. If you still want to delete these pictures, clear the protection as described above.
- Even protected pictures are deleted when you format the memory card.

**Deleting Images**

Pictures on the memory card and in the internal memory can be deleted at any time, either individually, several at a time, or all at once.

**Opening the delete menu** *Fig. 71 a/b***Deleting single pictures** *Fig. 72 a/b*

## Deleting multiple pictures **Fig. 73 a-e**

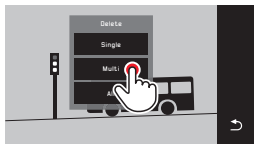


Fig. 73 a

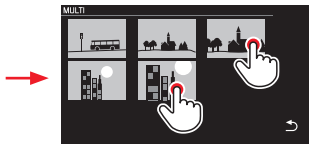


Fig. 73 b



Fig. 73 c

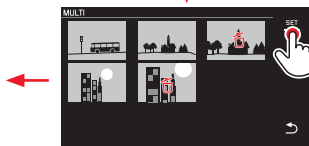


Fig. 73 d

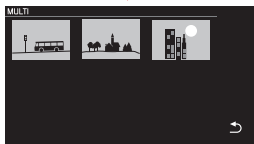


Fig. 73 e

## Deleting all pictures **Fig. 74 a/b**

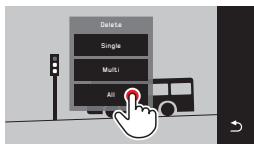


Fig. 74 a

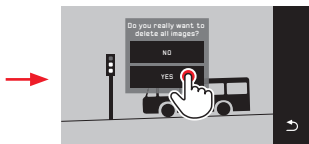


Fig. 74 b

### Notes:

- For **SINGLE** only:  
After deleting, the next picture appears. If the picture is protected, it continues to be displayed, and the message **This image is protected** appears briefly.
- For **MULTI** only:  
Pictures already marked as protected cannot be marked for deleting. If you attempt to do this, a corresponding message appears briefly.
- For **ALL** only:  
When deleting is complete, the message **No valid image to play** appears. If deleting cannot be carried out, the original picture is displayed again.
- When deleting multiple or all pictures, a corresponding information screen may appear due to the time required to process the data.
- If the pictures included some with delete protection, **Protected images were not deleted** appears briefly. The first of these protected pictures is then displayed.  
For protected pictures, the delete protection must first be cleared before they can be deleted.
- The delete and protection functions always relate exclusively to pictures from the source (memory card/internal memory) you have selected in the review menu.

### Important:

Pictures cannot be retrieved once they have been deleted.

## Selecting the review source Fig. 75 a-c

### Note:

This function is only available if a memory card is inserted.

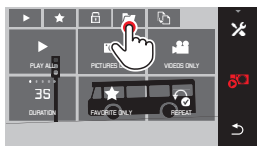


Fig. 75 a

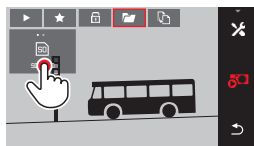


Fig. 75 b

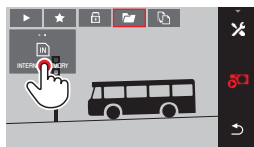






Fig. 75 c

The selected source determines not only which pictures are displayed, but also which pictures the , ,  and  functions apply to.

## Copying picture data between the internal memory and the inserted memory card

If a card is inserted, the Leica TL2 saves the picture data to the card, and if no card is inserted, the internal memory is used. You can copy the picture data at any time from its original location to the other - provided the destination has sufficient capacity available. The copy direction is determined by the selected review source: If the internal memory is selected, data is copied from there onto the memory card, and vice versa.

## Copying all pictures/pictures marked as favorites Fig. 76 a/b

The procedure is the same for both functions. The only difference is whether you select **FAVORITES ONLY**, as in the example, or **ALL**.

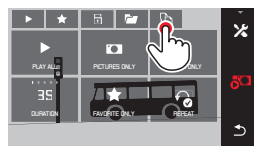


Fig. 76 a

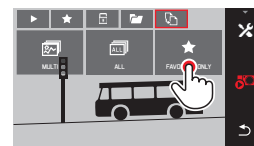
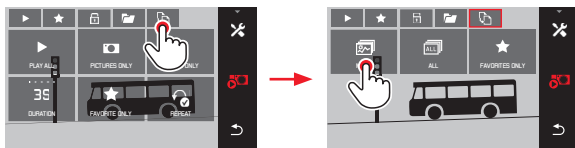


Fig. 76 b

Processing of the data begins after around 3 s.

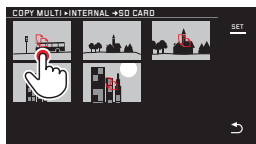
- Because of the time required, a corresponding information screen appears. When the copy operation is complete, a confirmation message appears.

## Copying multiple pictures **Fig. 77 a-e**

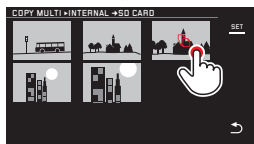


**Fig. 77 a**

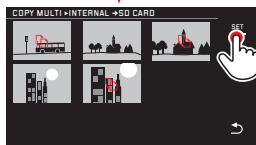
**Fig. 77 b**



**Fig. 77 c**



**Fig. 77 d**



**Fig. 77 e**

Processing of the data begins after around 3 s.

- Because of the time required, a corresponding information screen appears. When the copy operation is complete, a confirmation message appears.

From **Fig. 77 c** onwards, you can select the desired pictures using the setting dials, as an alternative to gesture control.

- The **SET** display is replaced with **COPY**.

Approx.: 2 s after your last marking, the display returns and you can continue with **Fig. 77 e**.

## Video review

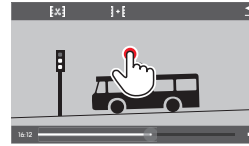
If a video recording is selected, **PLAY ▶** appears on the monitor.

### Starting playback **Fig. 78**

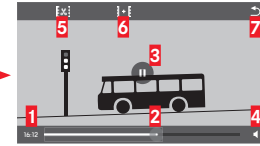


**Fig. 78**

### Calling up the video and audio control symbols **Fig. 79 a/b**



**Fig. 79 a**



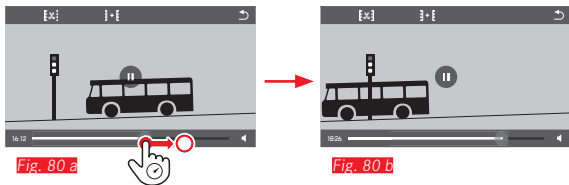
**Fig. 79 b**

- 1** Elapsed time
- 2** Scroll bar with contact area
- 3** Break
- 4** Volume
- 5** Shorten video
- 6** Combine two videos
- 7** Back to beginning of video

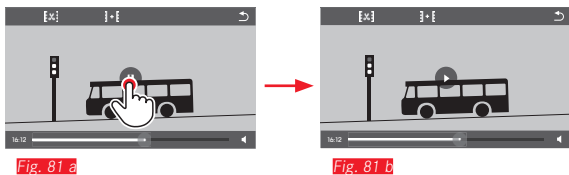
#### **Note:**

The control symbols disappear after 3s.

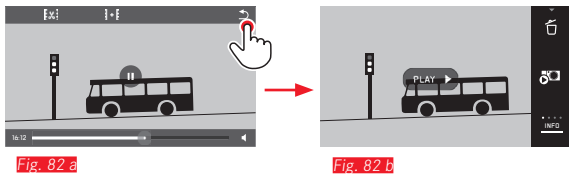
### Continuing playback from a particular point **Fig. 80 a/b**



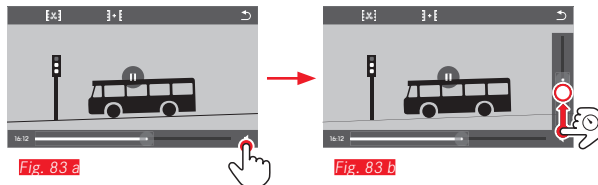
### Pausing playback **Fig. 81 a/b**



### Stopping playback **Fig. 82 a/b**



### Adjusting the volume **Fig. 83 a/b**



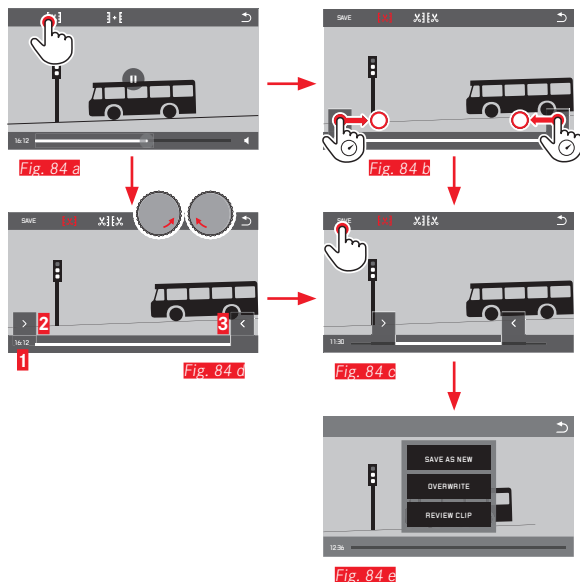
#### Note:

The sound is muted at the lowest position of the bar and the volume symbol will switch to .

## Cutting and combining video clips

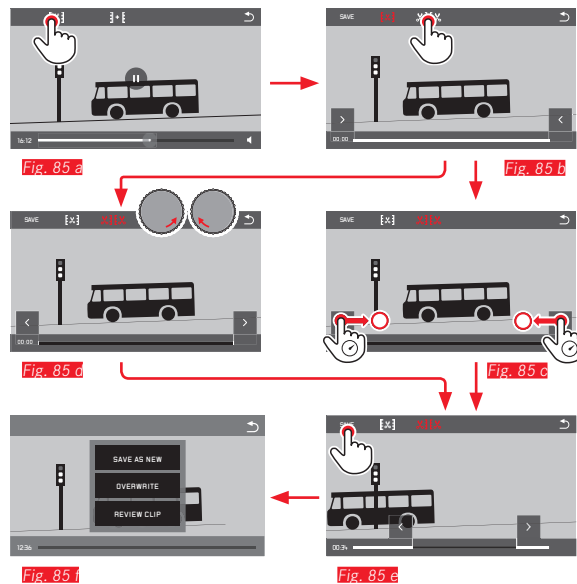
The Leica TL2 provides two different options for cutting a video recording.

### Cutting starting and/or end sections Fig. 84 a-c



- ▶ Operation continued on next page, right-hand column.

### Cutting out a particular scene Fig. 85 a-i



- During the operation, both the time (1) and a still shot of the selected start and end points (2/3) are displayed

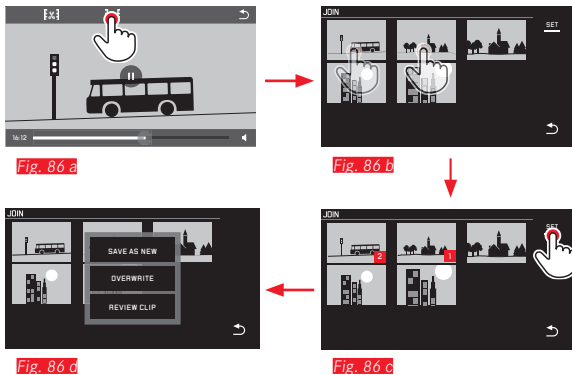
- ▶ Operation continued on next page, right-hand column.

#### Note:

You can cut in 1 s increments, therefore the initial video must have a length of at least 3s.



## Combining two video recordings Fig. 86 a-c



- ▶ Operation continued in right-hand column.

### Note:

Two videos can be selected for each combination operation. The order is indicated by 1 and 2.

When cutting and when combining videos, the operation continues by selecting one of the three options in the submenu Fig. 84 e, 85 f, 86 d and the process is the same.

- ▶ Select **SAVE AS NEW**  
The new video is also saved and the original is retained.
- ▶ Select **OVERWRITE**  
The new video is saved and the original is deleted.
- ▶ Select **REVIEW CLIP**  
The new video is shown. It is not saved and the original is not deleted.
- In all three cases, a corresponding information screen initially appears due to the time required to process the data, followed by the initial scene of the new video.

## MISCELLANEOUS

### USER PROFILES

On the Leica TL2, any combination of menu settings can be permanently stored, e.g. so that they can be retrieved quickly and easily at any time for recurring situations/subjects. A total of three memory slots are available for these combinations. Of course, you can reset all menu options to the factory default settings (**Default Profile**).

#### Creating profiles

- ▶ Set the desired functions in the menu

- ▶ In the main menu, select



- ▶ Select



- ▶ In the submenu, select **Save as Profile**

- ▶ In the **Save as Profile** submenu, select the desired profile slot

### Applying profiles

- ▶ In the main menu, select



- ▶ Select





- ▶ Select **Load Profile** in the submenu

- ▶ In the **Load Profile** submenu, select the desired profile slot, or **Default Profile**

#### Notes:



- By selecting **Default Profile** you can access the factory settings at any time even if other menu settings have been saved in one or more of the three profile slots.
- Unlike the **RESET** function explained in the section “Resetting all custom settings”, your settings for time, date and language are not reset with **Default Profile**.

## Renaming profiles

- ▶ In the main menu, select 
- ▶ Select 
- ▶ Select **Rename Profile** in the submenu
- ▶ In the **Rename Profile** submenu, select the desired profile slot
- ▶ In the corresponding keypad submenu, enter the new name using touch control to select the desired characters

## Transferring profiles from/to a card

You can either copy the profile slots to the memory card, or, vice-versa, from a memory card to the camera. Both procedures are performed in principally the same way.



- ▶ In the main menu, select 
- ▶ Select 
- ▶ Select **Export Profile** or **Import Profile** in the submenu
  - A confirmation prompt appears
- ▶ Confirm the ex-/import - **YES** or reject - **NO**

### Note:

When exporting, all profile slots are transferred to the card, i.e. including any empty profiles. As a result, when importing profiles any existing profiles in the camera will be overwritten, i.e. deleted.

## RESETTING ALL CUSTOM SETTINGS

This function allows you to reset all custom settings previously made in the menu at once and restore the factory default, if so desired with the exception of the WiFi settings and/or those in the profiles:



- ▶ In the main menu, select  **GENERAL**
- ▶ Select  **RESET**
  - A confirmation prompt appears
- ▶ Confirm the reset - **YES** or reject - **NO**
  - A confirmation screen concerning the WiFi settings appears.
- ▶ Confirm deleting the WiFi settings - **NO** or reject - **YES**
  - A confirmation screen concerning the profile settings appears.
- ▶ Confirm deleting the settings - **NO** or reject - **YES**

### Note:

This reset also applies to the settings in **Date/Time** and **Language**. The next time the camera is turned on, the welcome video is played again. For details of what to do next, refer to the "Menu language", and "Date/Time" sections.

## RESETTING THE IMAGE FILE NUMBERING

The Leica TL2 saves picture files with ascending numbers and stores them in automatically created folders. The names of the picture files are therefore made up of eight characters, "L" for the (Leica) camera, three figures for the folder, and four figures for the picture, e.g. „L1001234“. You can reset this numbering at any time:

- ▶ In the main menu, select 
- ▶ Select 
  - A confirmation prompt appears
- ▶ Confirm - **YES** or reject - **NO**

When you reset the numbering, or if the current folder contains the picture file number 9999, a new folder is automatically created and the numbering starts over. Example: Last picture before reset "L1009999", first picture afterwards "L1010001". For example, you can use this to sort your picture files more clearly.

The next available number is always used as the folder number, and a maximum of 999 folders are possible.



If the number capacity is reached at "L9999999", a corresponding warning message appears in the monitor and the numbering has to be reset.

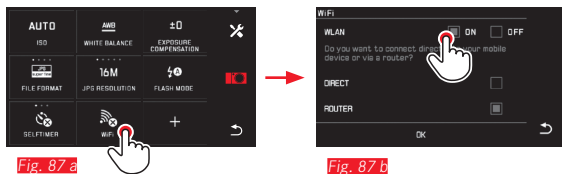
### Notes:

- If a memory card is inserted, the numbering is only reset on the card; if no card is inserted the internal memory numbering.
- If the memory card used already contains a picture file with a higher number than the last number assigned by the camera, the numbers are incremented according to the numbering on the card.
- To reset the folder number to 100, format the memory card or the internal memory and then immediately reset the image number. This also resets the picture number (to 0001).

## SETTING UP AND USING THE WIFI FUNCTION

Activating the WiFi function on the camera [Fig. 87 a/b](#)

- ▶ In the main menu, select 
- ▶ Select 
- ▶ In the **WLAN** submenu, select **ON**



There are various ways of communicating with the Leica TL2 via WiFi.

- **DIRECT** if no WiFi network is available
- or **Router** to incorporate the Leica TL2 in an available WiFi network.

To be able to access the pictures on your Leica TL2, you can choose between the platform-independent connection

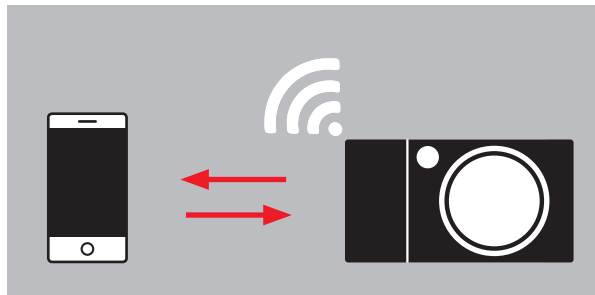
- **Web Gallery** and
- **APP Connection**.

With the **Web Gallery** function, you can very easily access your camera using a web browser. **APP Connection** enables more comprehensive functions.

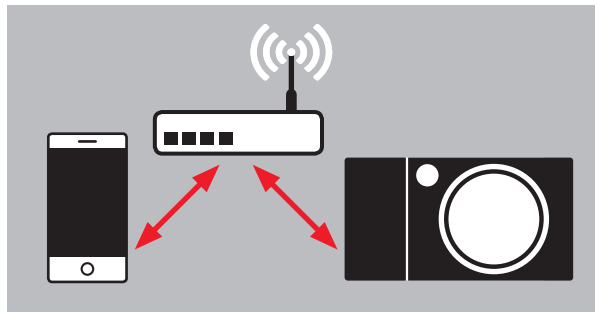
### Note:

The Leica TL app is available in the Apple™ App Store™/Google™ Play Store™.

### DIRECT

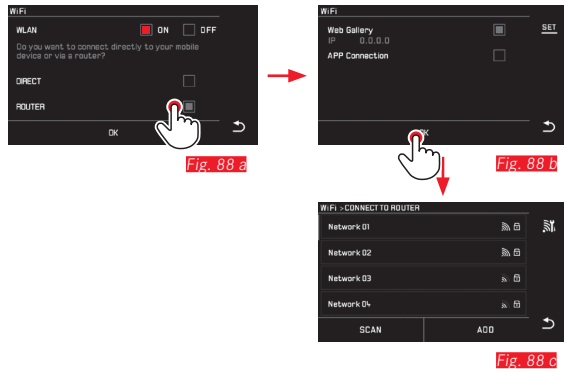


### ROUTER

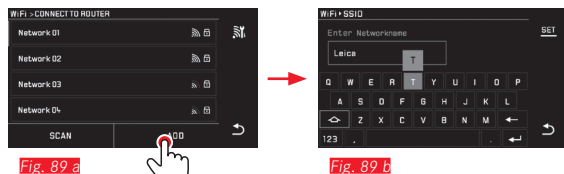


## Selecting a network **Fig. 88 a/c**

Select the network you want from the list displayed on the monitor by touching it. If the relevant network does not appear in the list immediately, you can start another search for available networks by touching the **SCAN** button.



Touching the **ADD** button allows you to add "hidden" networks by entering the network name **Abb. 89 a/b**. Use the keyboard displayed on the monitor to do this.

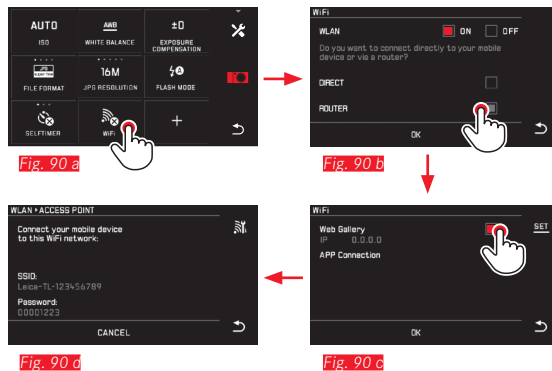


## Enter access data

Pressing the **IP Settings** button takes you to the corresponding submenu. If required, you can enter a fixed IP address and subnet mask for the camera by touching the **MANUAL** button here. However, these two settings are normally supplied automatically by the WLAN. Enter the corresponding password in the **Password** field to access the relevant network. If no password is set for the network, you can leave this field blank.

## Access with a web browser (**Web Gallery**) **Fig. 90 a-d**

In the address line of the web browser enter the (IP) address that is displayed on the monitor. You can then view and download the pictures on the camera.



## Access with the Leica TL App (APP Connection)



First of all, select the desired connection method in the camera menu.

- For a direct connection to a smart phone or tablet:
  - ▶ Select **DIRECT**
  - ▶ Then **APP Connection**
  - ▶ The network name - **SSID** and the **Password** are displayed on the camera monitor.
  - ▶ Select the desired Leica TL2 from the network list on your smartphone or tablet.
- For connection via an available WiFi network:
  - ▶ Select **ROUTER**
  - ▶ Then **APP Connection**
  - ▶ Select the desired WiFi network from the list of available networks
  - ▶ Enter access data (user/password).

Subsequent connections are established automatically. If you want to connect the app to another Leica TL2, select **DISCONNECT** and continue as described above to establish the new connection.

## Managing networks Fig. 91 a-c

The settings for different networks can be deleted using the **MAN-AGE NETWORKS** option in the WiFi menu. This is recommended for WLAN networks that you use infrequently or only once. Connected networks are indicated by a symbol (✓).

- ▶ In the main menu, select 
- ▶ Select 
- ▶ Select ✕ in the submenu
- ▶ Select **MANAGE NETWORKS**

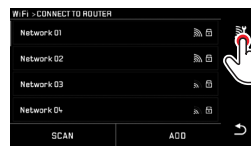


Fig. 91 a

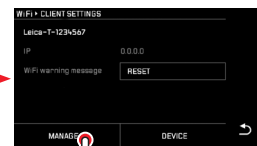


Fig. 91 b



Fig. 91 c



## Changing network names on the Leica TL2 Fig. 92 a-d

You can create a custom network name for your Leica TL2 (factory default setting: **Leica TL2Camera Serial Number**). To do this, touch the **DEVICE** symbol in the WiFi menu on the camera.

▶ In the main menu, select 

▶ Select 

▶ Select  in the submenu

▶ Select **Device**

### Note:

The characters "A to Z", "a to z", "0 to 9", and "-" are available for the name. Blanks cannot be used.

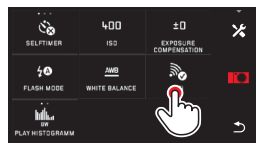


Fig. 92 a

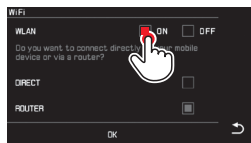


Fig. 92 b



Fig. 92 c



Fig. 92 d

### Notes:

- With WiFi access, pictures are only transferred in 2 MP resolution. To access the original data, you should connect the camera with a USB cable or insert the SD card into an SD card reader.
- Always connect the camera only to secure networks in order to prevent unauthorized access to your camera and data.
- The WiFi function requires slightly more power. We therefore recommend that you deactivate the function when it is no longer required.
- If there is an active USB connection between the camera and a computer, the WiFi function is disabled on technical grounds.
- There is no access control for the **Web Gallery** connection method. Therefore, make sure that you are working in a secure WLAN network.

## TRANSFERRING DATA TO A COMPUTER

### Using a USB cord/Using the camera as an external drive

The Leica TL2 is compatible with the following operating systems:

Microsoft®: Vista® 7®/8®

Apple® Macintosh®: Mac® OS X (10.6) and later

The camera is equipped with a super-speed USB 3.0 interface for transferring data.

#### With Windows operating systems:

The operating system detects the camera as an external drive and assigns it a drive letter. Transfer the picture data to your computer using Windows Explorer and save it.

#### With Mac operating systems:

The camera appears as a storage medium on the desktop. Transfer the picture data to your computer using Finder and save it.

#### Important:

- Use only the USB cable supplied.
- While data is being transferred, the USB cable must not be disconnected as otherwise the computer and/or the camera may crash. and may even cause irreparable damage to the memory card.
- The camera must not be turned off or automatically shut itself down due to a lack of battery power while data is being transferred, as this can cause the computer to crash.
- For the same reason, the battery must never be removed from the camera while the connection is active. If the battery capacity deteriorates while data is being transferred, the INFO screen appears with the battery capacity flashing. In this case cancel the data transfer, turn off the camera, and charge the battery.

#### Using a card reader



Picture data can also be transferred using card readers for SD/SDHC/SDXC memory cards. Compatible external card readers are available for computers with a USB interface.

#### Note:

Your Leica TL2 is equipped with an integrated sensor to detect the camera directionality – horizontal or vertical (both directions) – used for each exposure. This information allows the pictures to always be automatically displayed upright when subsequently displayed on a computer running the appropriate programs.

## FORMATTING

On the Leica TL2, the picture data in the internal memory and on an inserted memory card can be deleted separately. For memory cards, it is not normally necessary to format cards that have already been inserted. However, if a card that has yet to be formatted is inserted for the first time, it must be formatted. In such cases, the corresponding confirmation prompt appears automatically. Nevertheless, it is recommended that the internal memory and memory cards be reformatted occasionally, as a certain amount of residual data (info accompanying pictures) can take up memory capacity.

- ▶ In the main menu, select 
- ▶ Select 
- ▶ Call up the relevant submenu
  - A confirmation prompt appears
- ▶ Confirm - **YES** or reject - **NO**

## Notes:

- When formatting the memory card, the data on it is irretrievably lost.
- You should therefore get into the habit of transferring all your pictures onto a secure bulk storage medium, e.g. the hard drive on your computer, as soon as possible.
- Do not turn off the camera while the operation is in progress.
- If the memory card has been formatted in another device, such as a computer, you should reformat it in the camera.
- If the memory card cannot be formatted, you should ask your dealer or the Leica Product Support for advice.
- Files on the card marked with delete protection will not similarly be lost in formatting.

## USING RAW DATA (DNG)

You will need the right software if you want to edit data in DNG format, e.g. the professional raw data converter Adobe® Photoshop® Lightroom®. The software allows you to convert stored raw data in excellent quality and also offers quality optimized algorithms for digital color processing which create very low noise results coupled with astonishingly high resolution. During editing, you can adjust parameters like gradation, sharpness etc. to achieve the best possible image quality.

## INSTALLING FIRMWARE UPDATES

Leica is constantly working on developing and optimizing its products. As digital cameras have many functions that are purely controlled electronically, some of these improvements and enhancements to the functions can be installed on the camera at a later date. For this purpose, Leica offers firmware updates at irregular intervals that are made available to you on our website for download. Once you have registered your camera, Leica will notify you of all new updates.

Further information on registration and firmware updates for your camera, as well as any amendments and additions to the details provided in these instructions, can be found in the “Owners’ Login” area at: <https://owners.leica-camera.com>

To identify which firmware version is installed:

- ▶ In the main menu, select



- ▶ Select



- The current version number on the camera is displayed in the first line of the submenu.

The second line of the submenu provides access to a display of various country-specific approval symbols and numbers.

- ▶ Select **Regulatory information** in the submenu.

- The two-page display appears.

## SAFETY AND CARE INSTRUCTIONS

### GENERAL SAFETY INSTRUCTIONS

Do not use your camera in the immediate vicinity of devices with powerful magnetic, electrostatic or electromagnetic fields (e.g. induction ovens, microwave ovens, television sets or computer monitors, video game consoles, cell phones, radio equipment).

- If you place the camera on or very close to a television set, its magnetic field could interfere with picture recordings.
- The same applies to use in the vicinity of cell phones.
- Strong magnetic fields, e.g. from speakers or large electric motors, can damage the stored data or the pictures.
- If the camera malfunctions due to the effects of electromagnetic fields, remove the battery and then turn the camera on again. Do not use the camera in the immediate vicinity of radio transmitters or high-voltage power lines. Their magnetic fields can also interfere with picture recordings.
- Protect the camera from contact with insect sprays and other aggressive chemicals. Petroleum spirit, thinner and alcohol may not be used for cleaning. Certain chemicals and liquids can damage the camera's housing or the surface finish.
- As rubber and plastics sometimes emit aggressive chemicals, they should not remain in contact with the camera for a long time.

- Ensure that sand and dust cannot get into the camera, e.g. on the beach. Sand and dust can damage the camera and the memory card. Take particular care when inserting and removing the card.
- Ensure that water cannot get into the camera, e.g. when it is snowing or raining and on the beach. Moisture can cause malfunctions and even irreparable damage to the camera and the memory card.
- If salt water spray gets onto the camera, wet a soft cloth with tap water, wring it out thoroughly and wipe the camera with it. Then wipe down thoroughly with a dry cloth.

#### Important:

Use only the accessories specified and described in these instructions or by Leica Camera AG with the camera.

#### Monitor

- If the camera is exposed to significant temperature fluctuations, condensation can form on the monitor. Wipe it off carefully with a soft dry cloth.
- If the camera is very cold when turned on, the monitor image will initially be slightly darker than normal. As soon as the monitor warms up, it will reach its normal level of brightness.

The monitor is manufactured using a high-precision process. This ensures that of the total of around 920,000 pixels more than 99.995% work correctly and only 0.005% remain dark or are always bright. However, this is not a malfunction and it does not impair the reproduction of the picture.

### Picture sensor

- Cosmic radiation (e.g. during flights) can cause pixel defects.

### Condensation

If condensation has formed on or in the camera, you should turn it off and leave it to stand at room temperature for around an hour. Once the camera temperature has adjusted to room temperature, the condensation will disappear by itself.

### Care instructions

- As any soiling also represents a growth medium for microorganisms, you should take care to keep the equipment clean.

### For the camera

- Only clean the camera with a soft, dry cloth. Stubborn dirt should first of all be covered with a well-thinned cleaning agent and then wiped off with a dry cloth.
- To remove marks and fingerprints, wipe the camera with a clean lint-free cloth. Tougher dirt in hard to reach corners of the camera body can be removed with a small brush.
- All mechanically operated bearings and sliding surfaces on your camera are lubricated. Please remember this if you will not be using the camera for a long period of time. To prevent the lubrication points becoming gummed up, the camera shutter should be operated several times every three months. We also recommend repeated adjustment and use of the setting dials.

### For lenses

- Normally, a soft hair brush is sufficient to remove dust from the outer lens elements. However, in case of more stubborn dirt, they can be carefully cleaned with a very clean, soft cloth that is completely free of foreign matter, using circular motions from the inside to the outside. We recommend micro-fiber cloths (available from photographic and optical specialists) that are stored in a protective container and can be washed at temperatures of up to 40°C/104°F (without fabric softener, never iron!). Cloths for cleaning spectacles that are impregnated with chemicals should not be used as they can damage the lens glass.
- The lens hood supplied also protects the lens from unintentional fingerprints and the rain.

### For the battery

Rechargeable lithium ion batteries generate power through internal chemical reactions. This reaction is influenced by ambient temperature and humidity. Very high or low temperatures reduce the life of the battery.

- Always remove the battery if you will not be using the camera for a long period of time, As otherwise it could become totally discharged after several weeks, i.e. its voltage drops to a very low level.
- Lithium ion batteries should only be stored partly charged, i.e. not when fully discharged or fully charged. For very long storage periods, the battery should be charged for around 15 minutes twice a year to prevent total discharge.

- Always ensure that the battery contacts are clean and freely accessible. Whilst lithium ion batteries are secured against short circuits, they should still be protected against contact with metal objects like paper clips or jewelry. A short-circuited battery can get very hot and cause severe burns.
- In order to charge the battery, it must have a temperature of between 0°C and 35°C/32°F and 95°F (otherwise the charger may not turn on or off again).
- If a battery is dropped, check the casing and the contacts immediately for any damage. Using a damaged battery can damage the camera.
- Batteries have only a limited service life.
- Send defective batteries to an appropriate collection point for proper recycling.
- Never throw batteries into a fire as this can cause them to explode.

#### **For the charger**

- If the charger is used in the vicinity of radio receivers it can interfere with reception; maintain a distance of at least 1 m / 3 ft between the devices.
- When the charger is in use, it can make a noise (buzzing) – this is quite normal and is not a malfunction.
- When it is not in use, disconnect the charger from the mains as otherwise it uses a certain (very small) amount of power even when no battery is inserted in it.
- Always keep the charger contacts clean, and never short circuit them.

#### **For memory cards**

- While a picture is being stored or the memory card is being read, it must not be removed, and the camera must not be turned off or exposed to vibrations.
- Make sure to store memory cards in their anti-static container when not in use.
- Do not store memory cards where they will be exposed to high temperatures, direct sunlight, magnetic fields or static discharge.
- Do not drop or bend memory cards as this can damage them and result in loss of the stored data.
- Always remove the memory card if you will not be using the camera for a long period of time.
- Do not touch the connections on the rear of the memory card and keep them free of dirt, dust and moisture.
- It is recommended that the memory card be reformatted from time to time, as fragmentation occurs when deleting, which can block some of the memory capacity.

## Storage

- If you are not using the camera for a longer period of time, we recommend that you:
  - a. Turn it off,
  - b. Remove the memory card, and
  - c. Remove the battery
- A lens works like a magnifying glass if bright sunlight shines on the front of the camera. The camera must therefore never be stored without lens protection. Using the lens cap and keeping the camera in the shade (or immediately putting it away in the case) will help prevent damage to the interior of the camera.
- You should preferably store the camera in a closed and padded container so that nothing can damage it and it is protected from dust.
- Store the camera in a dry, adequately ventilated place, where neither high temperatures nor high humidity will occur. When used in humid conditions, the camera should be completely free of all moisture before being stored away.
- Photo cases that became wet during use should be emptied to prevent damage to your equipment caused by moisture and any leather-tanning residue released.
- To prevent fungal growth during use in hot, humid tropical climates, the camera equipment should be exposed to the sun and air as much as possible. Storage in airtight containers or cases is recommended only if a desiccant such as silica gel is used.
- To prevent the formation of fungus, do not store the camera in a leather case for extended periods of time.
- Note down the serial number of your Leica TL2, as this is extremely important in case of loss.

## Safety notes on using carrying straps

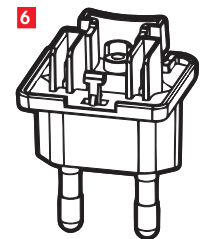
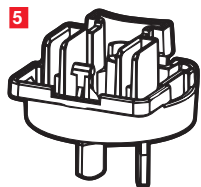
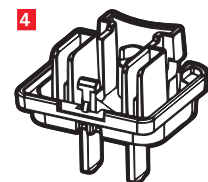
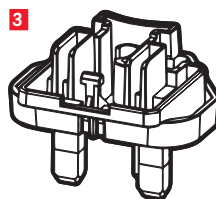
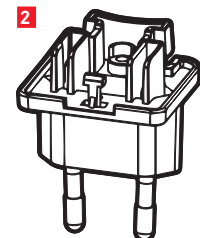
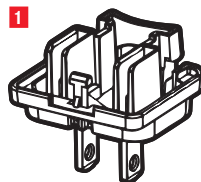
- Carrying straps are usually made of strong material. There is therefore a risk of strangulation.
- Use them only for their intended purpose as a carrying strap on a camera/on binoculars. Any other use carries the risk of injury and may possibly result in damage to the carrying strap and is therefore not permitted.
- Due to the risk of strangulation, carrying straps should not be used for cameras/binoculars during sporting activities where there is a high risk of getting caught by the carrying strap (e.g. climbing in the mountains and comparable outdoor sports).
- Keep carrying straps away from children. They are not toys and are potentially dangerous for children. Due to the risk of strangulation, it is not suitable for children to use them as carrying straps for cameras/binoculars.



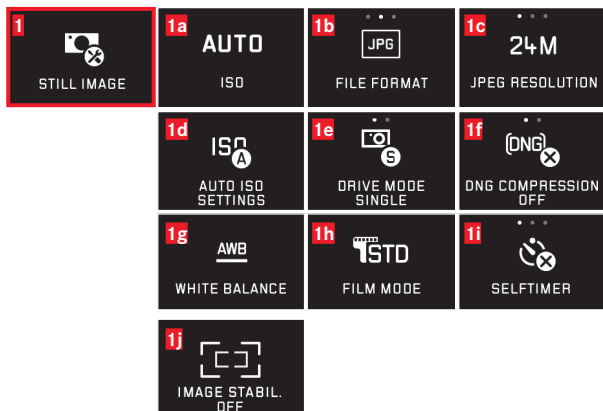
## APPENDIX

### CHARGER ADAPTER PLUGS

Plug	Country
<b>1</b> US/Japan	USA Canada Japan Singapore Thailand Taiwan
<b>2</b> EU	EU Turkey Russia
<b>3</b> UK	UK Qatar UAE Hong Kong Malaysia South Africa Malta
<b>4</b> China	China
<b>5</b> Australia	Australia New Zealand
<b>6</b> Korea	Korea



## MAIN MENU



## Function groups

1	Still image settings
2	Exposure setting
3	Sharpness settings
4	Video settings
5	Wireless connection settings
6	Monitor/viewfinder settings
7	Review settings
8	Basic camera settings
9	Flash settings

## Still image settings

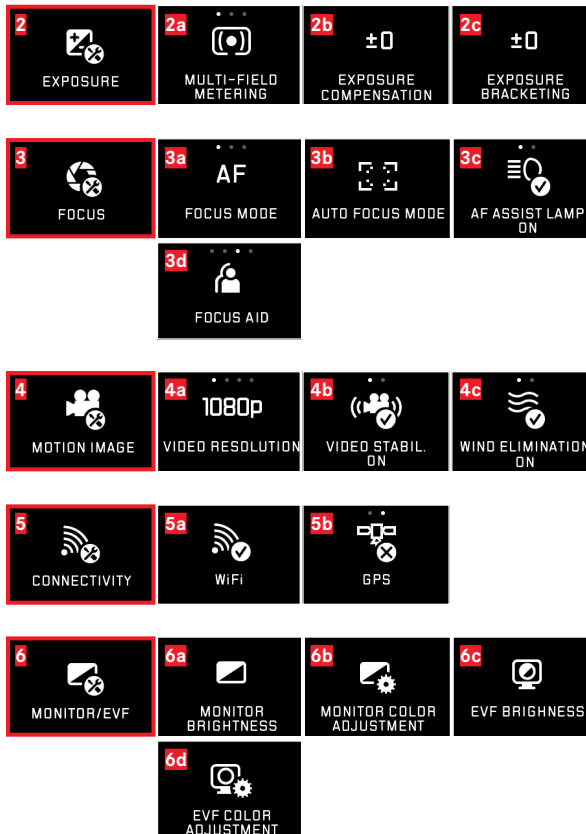
	MY CAMERA <sup>1</sup>	Page
1a	x	146
1b	x	144
1c	x	144
1d		146
1e		150
1f		144
1g	x	145
1h		146
1i	x	148
1j		148

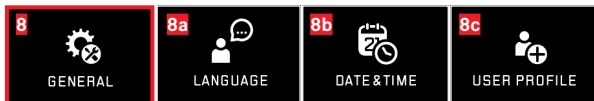
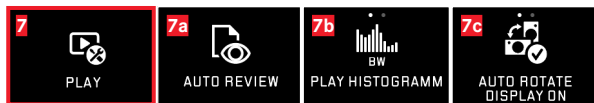
<sup>1</sup> X = Menu items in **MY CAMERA** menu in the default settings

<sup>2</sup> Only available with appropriately equipped Leica SL lenses

	MY CAMERA <sup>1</sup>	Page
<b>Exposure settings</b>		
<b>2a</b>	Exposure metering method	x 158
<b>2b</b>	Exposure compensation	x 166
<b>2c</b>	Automatic bracketing	167
<b>Sharpness settings</b>		
<b>3a</b>	Focusing mode	150
<b>3b</b>	Autofocus mode	152
<b>3c</b>	Autofocus auxiliary light	151
<b>3d</b>	Manual focusing aid	156
<b>Video settings</b>		
<b>4a</b>	Video resolution	172
<b>4b</b>	Image stabilization	173
<b>4c</b>	Wind noise damping	173
<b>Wireless connection settings</b>		
<b>5a</b>	WiFi connection	x 192
<b>5b</b>	GPS connection <sup>3</sup>	149
<b>Monitor/viewfinder settings</b>		
<b>6a</b>	Monitor brightness	142
<b>6b</b>	Monitor color reproduction	142
<b>6c</b>	Viewfinder brightness <sup>3</sup>	142
<b>6d</b>	Viewfinder color reproduction <sup>3</sup>	142

<sup>3</sup> Only available with attached viewfinder Leica Visoflex (Typ 020)





## Review settings

Page

<b>7a</b>	Automatic review	174
<b>7b</b>	Histogram display	163
<b>7c</b>	Automatic image alignment	175

## Basic camera settings

<b>8a</b>	Menu languages	140
<b>8b</b>	Date/time	140
<b>8c</b>	Managing user profiles	188
<b>8d</b>	Automatic Monitor Shutdown	142
<b>8e</b>	Automatic Camera Shutdown	143
<b>8f</b>	Acoustic feedback signals	142
<b>8g</b>	Formatting	197
<b>8h</b>	Resetting picture numbering	191
<b>8i</b>	Resetting camera settings	190
<b>8j</b>	Technical camera information	113/199
<b>8k</b>	Function button	127/143/173

## Flash Settings<sup>4</sup>









<b>9a</b>	Flash mode	169
<b>9b</b>	Flash exposure compensation <sup>5</sup>	171
<b>9c</b>	Flash firing point	171

<sup>4</sup> Only available with attached flash

<sup>5</sup> Only available if attached flash does not allow direct setting

## EXPOSURE MODES

<b>10</b> P PROGRAM AE	<b>11</b> A APERTURE PRIORITY	<b>12</b> S SHUTTER PRIORITY
<b>13</b> M MANUAL	<b>14</b> SCN SCENE	

<b>14</b> SCN SCENE	<b>14a</b> AUTO AUTO	<b>14b</b>  SPORTS	<b>14c</b>  PORTRAIT
<b>14d</b>  LANDSCAPE	<b>14e</b>  NIGHT PORTRAIT	<b>14f</b>  SNOW/BEACH	
<b>14g</b>  FIREWORKS	<b>14h</b>  CANDLE LIGHT	<b>14i</b>  SUNSET	
<b>14j</b>  DIGISCOPING			

## Exposure control modes

Page

<b>10</b>	Automatic program	159
<b>11</b>	Aperture priority mode	160
<b>12</b>	Shutter speed priority	161
<b>13</b>	Manual setting	162
<b>14</b>	Scene modes	165

## Scene modes

<b>14a</b>	Advanced automatic program mode
<b>14b</b>	Sport program
<b>14c</b>	Portrait program
<b>14d</b>	Landscape program
<b>14e</b>	Portrait program for dark surroundings
<b>14f</b>	Program for exceptionally bright subjects
<b>14g</b>	Fireworks program
<b>14h</b>	Program for low ambient light
<b>14i</b>	Sunrise/sunset program
<b>14j</b>	Digiscoping program

## INDEX

Attaching the carrying strap .....	116
Automatic camera shutdown .....	141
Battery, inserting and removing .....	117
Cautions .....	199
Clipping .....	130/163
Color Rendering .....	179
Color saturation .....	146
Combining video recordings .....	186
Compression rate .....	144
Contrast .....	146
Copying picture data .....	182
Cutting video recordings .....	186
Deleting pictures.....	180
Detail, selection of the, see Review mode	
DNG .....	144/198
Electronic viewfinder.....	142/149
Enlargement of pictures during review .....	174
Exposure control	
Aperture priority mode .....	160
Automatic program .....	159
Bracketing function, automatic.....	167
Exposure compensation .....	166
Manual setting .....	162
Metering memory lock .....	166
Metering methods.....	158
Shift .....	159
Shutter speed priority.....	161
Scene modes .....	165
File format .....	144
Firmware downloads .....	198
Flash modes .....	168
Flash units .....	168
Focusing .....	150
AF auxiliary light.....	151
Autofocus .....	150
Focusing aids.....	156
Focusing by touching .....	154
Manual focusing.....	156
Metering methods.....	152
Formatting.....	197
Frame rate .....	150
Function button .....	127/143/173
Gesture control.....	128
GPS .....	149
Histogram.....	130/163
Information service, Leica Product Support .....	212
ISO Sensitivity.....	146
Leica Customer Care .....	212
Main switch .....	126
Marking pictures .....	179
Marking pictures as favorites .....	179
Memory card, inserting and removing.....	122
Menu language .....	140
Monitor.....	142
Noise (key tones) .....	142

Parts, designation .....	109	Time and date .....	140
Picture frequency .....	150	Transferring data to a computer .....	196
Picture series .....	150	Turning on/off, see main switch	
Profiles .....	188	USB connection .....	120/196
Protecting pictures/clearing delete protection .....	179	Video recording .....	172
Raw data .....	144/198	Viewfinder.....	142
Repairs/Leica Customer Care.....	212	Viewing the pictures, see Review mode	
Resetting all individual menu settings .....	190	Volume .....	142
Resolution.....	144	White balance .....	145
Review.....	174	WiFi .....	192
Review menu .....	178		
Scope of delivery .....	110		
Select source (for Review).....	182		
Self-Timer .....	148		
Setting dials.....	126		
Shutter button, see also Technical data.....	127		
Slide show .....	178		
Software .....	198		
Sound recording .....	173		
Stabilization.....	148/173		
Storage.....	202		

## TECHNICAL DATA

**Camera name** Leica TL2

**Camera type** Digital APS-C system camera

**Type-No.** 5370

**Order no.** 18 187 (silver), 18 188 (black)

**Lens mount** Leica L bayonet with contact strip for communication between lens and camera

**Compatible lenses** Lenses with Leica L-Mount, Leica M/R lenses using the Leica M-Adapter L/R-Adapter L

**Sensor** APS-C sized CMOS sensor (23.6 x 15.7 mm) with 24.96/24.32 million pixels (total/effective), aspect ratio 3:2

**Photo Resolution** DNG: 6016 x 4014 Pixels (24 Megapixels), JPEG: optional 6000 x 4000 Pixels (24 Megapixels), or 4272 x 2856 Pixels (12 Megapixels), or 3024 x 2016 Pixels (6 Megapixels)

**Photo file formats/compression rates** Optional: JPG, DNG, or DNG + JPG, DNG optionally uncompressed or compressed (lossless)

**Video recording format** MP4

**Video resolution/frame rate** 3840 x 2160 p (4K) 30fps, 1920 x 1080 p (FHD) 60 fps or 1280 x 720 p (HD) 120 fps or 1280 x 720 p (HD) 120 fps (SLOMO)

**Video recording time** Depending on ambient or housing temperature video recordings are possible up to a maximum length of 29 minutes, maximum file size is 4 GB, if a recording exceeds this limit, the respective part is automatically stored in another file

**Internal memory** 32 GB

**Storage media** SD/SDHC/SDXC memory cards, multimedia cards, UHS II-standard is supported

**ISO range** Automatic, ISO 100 to ISO 50000

**White balance** Automatic, presets for daylight, cloudy, halogen lighting, shadow, electronic flash, two memory slots for manually metered settings, manual color temperature setting

**Autofocus system** Contrast-based

**Autofocus metering methods** Single point, multi-zone, spot, face detection, touch AF

**Exposure modes** Automatic program, aperture priority, shutter speed priority, and manual setting, Fully automatic, sport, portrait, landscape, night portrait, snow/beach, fireworks, candlelight, sunset, digiscoping

**Exposure Metering Methods** Multi-zone, center-weighted, spot

**Exposure compensation** ±3 EV in 1/3 EV increments

**Automatic exposure bracketing** Three pictures in graduations up to ± 3EV, adjustable in 1/3 EV increments

**Shutter speed range** 30 s to 1/40000 s (up to 1/4000 s with mechanical, beyond that with electronic shutter)

**Picture sequence** Approx. 7 fps (with mechanical shutter) and 20 fps (with electronic shutter), 29 pictures at full speed, then depending on memory card properties

**Flash modes** Adjustable with attached, system compatible flash

**Flash exposure compensation** ±3 EV in 1/3 EV increments

**Flash synchronization** 1/180 s



**Monitor** 3.7" TFT LCD, 1.3 million pixels, 854 x 480 per color channel

**Self-Timer** Selectable delay time 2 or 12 s

**WLAN** Complies with IEEE 802.11b/g/n standard (standard WLAN protocol), channel 1-11, encryption method: WiFi-compatible WPA™/WPA2™

**Power supply** Leica BP-DC13 lithium ion battery, rated voltage 7.2 V, capacity 985 mAh (min.) (based on CIPA standard): approx. 250 pictures, charging time (after total diwscharge): approx. 160 min Manufacturer: Panasonic Energy (Wuxi) Co, Ltd. Made in China

**Interfaces** Micro (type D) HDMI port, HDMI 1.4b standard is supported, USB type C port, USB 3.0 Super Speed standard is supported, battery charging via USB connection possible with max. 1 A, accessory shoe with Leica flash interface with integrated connection for optional accessories

**Charger** Leica BC-DC13, input: AC 100-240V, 50/60Hz, 0.145 A (100 V)-0.08 A (240 V), automatic reversing, DC 8.4 V, 0.65 A, Weight: approx. 90 g/3.2 oz, Dimensions: approx. 96 x 68 x 28 mm, Manufacturer: Shenzhen Eng Electronics Co., Ltd., Made in China

**Body** Leica unibody aluminum design, attachment system for carrying straps and other accessories, ISO accessory shoe with center and control contacts for flash units or Leica Visoflex electronic viewfinders

**Tripod thread** A ¼ DIN 4503 (¼")

**Body dimensions (WxHxD)** 134 x 69 x 33 mm

**Weight** Approx. 399 g/355 g (with/without battery)

**Scope of delivery** Camera body, carrying strap, 2 release keys for removing the dummy plugs or e.g. the carrying strap, battery (Leica BP-DC13), charger (Leica BC-DC13) with 6 adapter plugs, USB type C cord

**Software** Leica App (free download in Apple™ App Store™/Google™ Play Store™)

## LEICA PRODUCT SUPPORT

The Product Support Department at Leica AG can answer any technical questions relating to Leica products, including support for the supplied software in writing, on the phone or by email. They are also the contact point for purchasing advice and to order instruction manuals. Alternatively, you can send us your questions using the contact form on the Leica Camera AG homepage.

Leica Camera AG  
Product Support/Software Support  
Am Leitz-Park 5  
35578 Wetzlar, Germany  
Tel.: +49(0)6441-2080-111 /-108  
Fax: +49(0)6441-2080-490  
info@leica-camera.com / software-support@leica-camera.com

## LEICA CUSTOMER CARE

The Leica Camera AG Customer Care department or the repair service provided by authorized Leica agents in your country are available for service, maintenance and repairs of your Leica equipment (see the warranty card for a list of addresses).

Leica Camera AG  
Customer Care  
Am Leitz-Park 5  
35578 Wetzlar, Germany  
Tel.: +49(0)6441-2080-189  
Fax: +49(0)6441-2080-339  
customer.care@leica-camera.com